

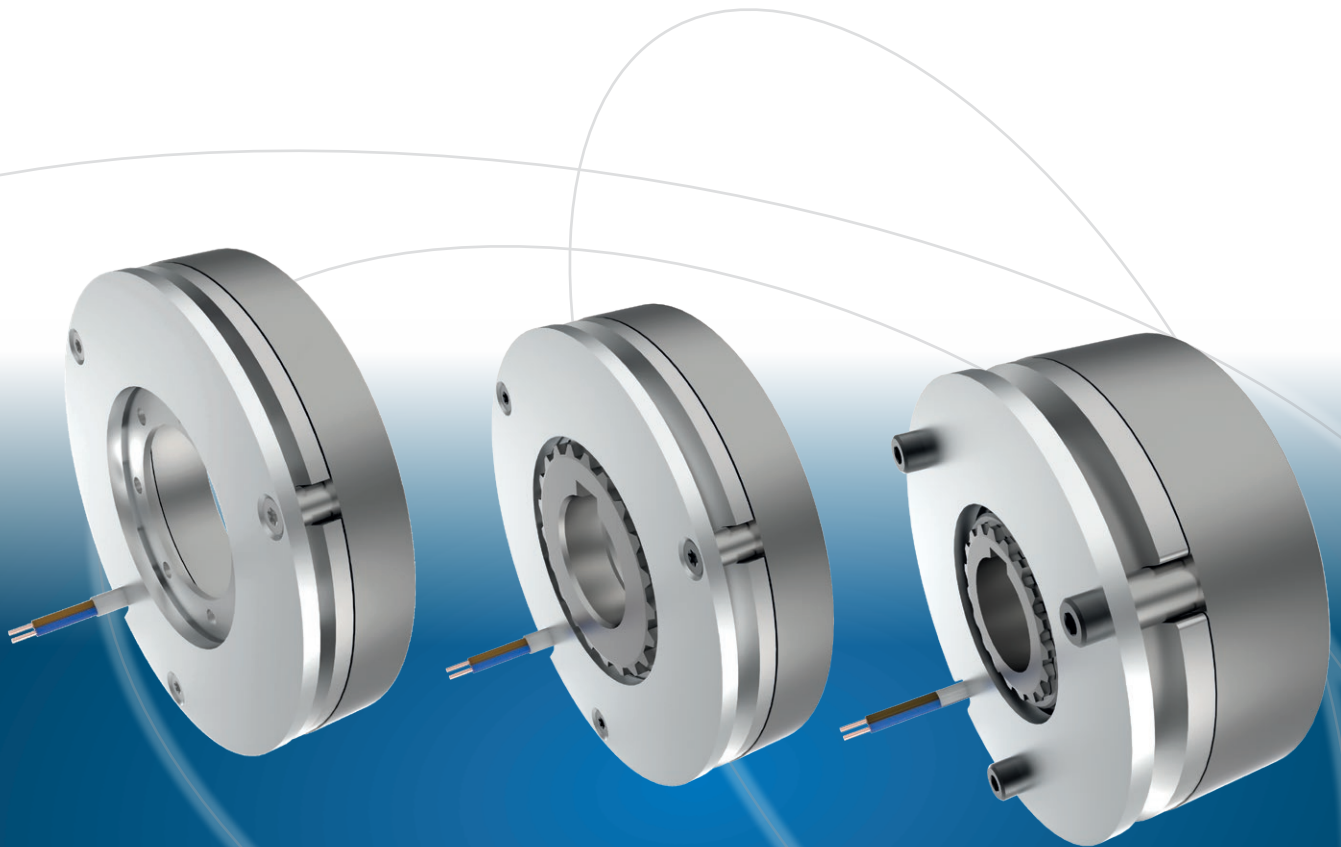

*your reliable partner*



**ROBA<sup>®</sup>-servostop<sup>®</sup>**

## ROBA<sup>®</sup>-servostop<sup>®</sup>

### The perfect safety brakes for servomotors and lightweight robots



#### Reliable function due to fail-safe principle

The spring applied ROBA<sup>®</sup>-servostop<sup>®</sup> is closed in de-energised condition. It provides the required braking torque even in the event of an emergency stop, a power failure or when the power supply is interrupted. To ensure that the ROBA<sup>®</sup>-servostop<sup>®</sup> brakes also provide sufficient friction work in emergency stop situations and brake movements with a defined braking torque, a friction lining developed for this purpose with a corresponding steel counter friction surface is required. While this is common with safety brakes, permanent magnet brakes with their steel-on-steel friction combinations reach their tribological limits here.

#### Reliable even at high temperatures

The braking torque is generated through special organic friction linings. These temperature-resistant linings impress with their high, even friction coefficients, and can also be used at high ambient temperatures of up to 120 °C.

#### Lightweight solution for robotics

In the *mayr*<sup>®</sup> modular system, users can choose between classic servo brakes in the motor, with hub and toothed rotor, in classic or slim constructional design. In addition, there is another slim and lightweight design variant, the ROBA<sup>®</sup>-servostop<sup>®</sup> Cobot, a pad solution with a large inner diameter. The latter is specially designed for integration into the robot joint. These solutions are particularly compact and convince with their low weight and ideal dynamic properties. But also the classic brakes with hub and toothed rotor can be customized and integrated directly into a joint.

#### High performance density and energy efficiency

The ROBA<sup>®</sup>-servostop<sup>®</sup> brakes are not only very lightweight, but also extremely fast when it comes to magnetic actuation. At the same time they display high performance density and wear resistance. Furthermore, the brakes impress users with their high permitted friction work during dynamic braking actions. In addition, the ROBA<sup>®</sup>-servostop<sup>®</sup> brakes are designed in such a way that the installation space is optimally used and as much energy as possible is saved.

#### Easy installation

The simple and ready-to-install design makes installation substantially easier. The operating air gap does not have to be adjusted. Exact axial positioning on the motor shaft is not required. The brake always operates accurately and reliably with a steady air gap and tolerates minor bearing backlash and temperature expansion. Installation errors are almost completely excluded.

#### Any installation position in servomotors

For servomotors, the brakes are preferably installed in the A-bearing shield, because the fixed bearing is located here and temperature expansions cannot influence the brake severely. The ROBA<sup>®</sup>-servostop<sup>®</sup> can also be integrated without restrictions into the B-bearing side of the motor, as temperature expansions and bearing backlash do not have a negative influence on the function and the reliability of the brake.

## ROBA®-servostop® – Overview of the series

### ROBA®-servostop® Classic

Classic series for installation into A- or B-bearing shield of servomotors

Type 8980.00\_00

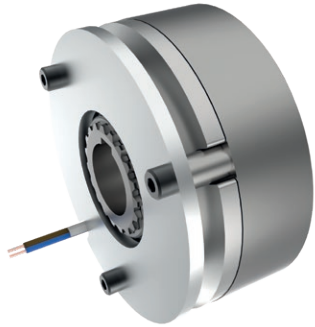

- High braking torque
- Wear-resistant - large number of emergency stops (dynamic brakings) are allowed
- Easy installation

#### Performance data

Nominal braking torque: 1.5 up to 100 Nm  
Max. speed: 3000 up to 9500 rpm

Page 4

### ROBA®-servostop® Lean

Slim series for installation into A- or B-bearing shield of servomotors

Type 8982.00\_01

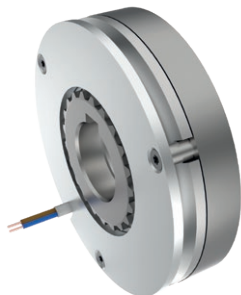

- Slim design
- Easy installation
- High performance density at low energy consumption
  - ➔ Operation with overexcitation and power reduction

#### Performance data

Nominal braking torque: 0.31 to 11.5 Nm  
Max. speed: 4500 up to 10500 rpm

Page 6

### ROBA®-servostop® Cobot

Proven series for lightweight robots

Type 8981.29\_01



- Can be integrated into even the smallest installation spaces
- Ideal for hollow shafts
- High performance density at low energy consumption
  - ➔ Operation with overexcitation and power reduction

#### Performance data

Nominal braking torque: 0.23 to 9 Nm  
Max. speed: 4500 up to 10500 rpm

Page 8

# ROBA®-servostop® Classic

## Type 8980.00100

Screw connection on the coil carrier front side

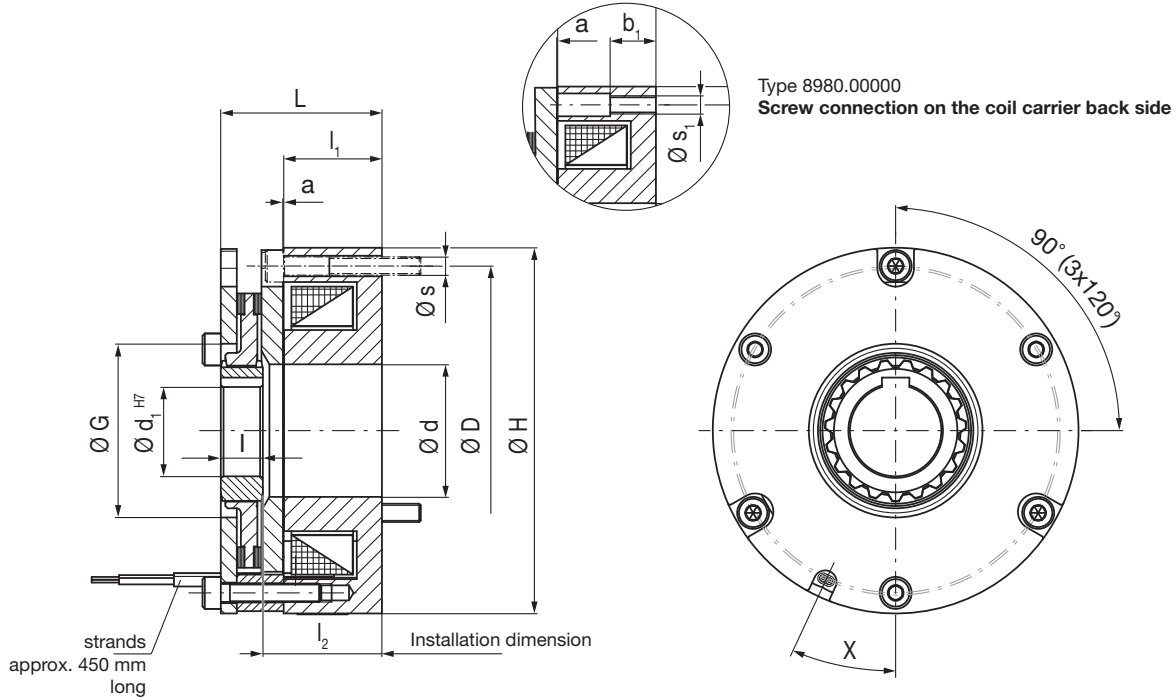

Technical Data			Size								
			50	60	70	80	90	100	120	140	160
Nominal braking torque <sup>1) 2) 3) 4)</sup>	$M_N$	[Nm]	1.5	3.1	5.3	7	9.8	15.5	30	60	100
Coil voltage	U	[VDC]	24	24	24	24	24	24	24	24	24
Electrical power	$P_{20}$	[W]	9.5	11.7	15.1	17.8	22.2	27.7	32.4	43.0	60.5
Maximum speed	$n_{max}$	[rpm]	9500	8000	7000	6500	5500	5000	4000	3500	3000
Max. idle speed		[rpm]	20000	16500	14500	12500	11500	9500	7500	6500	5500
Weight at $d_{1max}$		[kg]	0.34	0.47	0.66	0.89	1.29	1.7	2.66	4.37	6.11
Total mass moment of inertia at $d_{1max}$	J	[10 <sup>-6</sup> kgm <sup>2</sup> ]	2.59	5.65	11.54	17.94	30.95	71.88	182.02	438.96	895.57

Dimensions	Size									
	50	60	70	80	90	100	120	140	160	
a	0.15	0.15	0.15	0.15	0.2	0.2	0.2	0.2	0.25	
b <sub>1</sub>	7	7	10	10	12	12	12	14	14	
d	16	23	29	29	33	42	47	65	70	
d <sub>1 min</sub> <sup>5)</sup>	8	9	11	13	13	18	23	32	30	
d <sub>1 max</sub>	12	15	20	20	25	30	35	45	50	
D	46	56	64	72	80	90	112	132	150	
G	25	28	38	38	45	55	62	85	90	
H	52	62	72	80	90	102	124	147	166	
L	31.15	31.15	34.25	35.25	39.3	42.4	44.4	53.4	57.45	
l <sup>-0.2</sup>	7.4	8	9.2	9.2	10.5	11.8	13.5	17	29	
l <sub>1</sub>	20.5	19.5	20.5	21.5	23.5	25.5	24	28	31	
l <sub>2</sub>	23.75 ±0.15	23.15 ±0.15	25.05 ±0.2	26.05 ±0.2	28.8 ±0.3	30.6 ±0.3	30.9 ±0.3	36.4 ±0.5	28.45 ±0.5	
s	3.4	3.4	4.5	4.5	5.5	5.5	6.6	9	9	
s <sub>1</sub>	M3	M3	M4	M4	M5	M5	M6	M8	M8	
X	25°	25°	25°	25°	25°	25°	25°	25°	25°	

- 1) Braking torque tolerance: + 75 %
- 2) Suitable for a temperature of 0 up to 60 °C: For higher temperatures, please consider the following braking torque reductions:  
 >60 °C to 80 °C: 10 % reduction  
 >80 °C to 100 °C: 20% reduction  
 >100 °C to 120 °C: 30% reduction

For temperature -20 °C to 0 °C: Observe the "Ambient temperature/Climat conditions" section in the operational instructions!

3) The braking torque values are based on friction values determined in tests at mayr® power transmission. As a friction system is influenced by many parameters, such as mounting situation, temperature, ambient conditions, run-in condition, wear, switching work, sliding speed, aging, contamination, etc., deviating braking torques are possible. The specified nominal braking torque is a lower limit which is very likely to be reached, but cannot be guaranteed due to the many possible influences. The fluctuations in braking torques must be taken into account during dimensioning by providing appropriate safety measures. Especially for critical applications, it is important to consult mayr® power transmission and carry out an appropriate application check.

4) Remarks and recommendations regarding the dimensioning and selection of brakes (e.g., based on load torque and test torque) can be found in the operational instructions and may be provided on request from mayr® power transmission.

5) The respective maximum bores can be found in the table "Permitted hub bores" (page 11) according to the corresponding keyways and their tolerances.

## ROBA®-servostop® Classic – Installation Examples

### Screw connection on the coil carrier front side

The brakes are screwed on via threaded holes in the coil carrier and through holes, e.g., in the bearing flange (provided by the customer). The braking torque is transmitted into the hub via the tothing of the rotors. The hub must be fixed axially. Observe the installation dimensions! The braking torque is transmitted from the hub to the shaft via a key (provided by the customer).

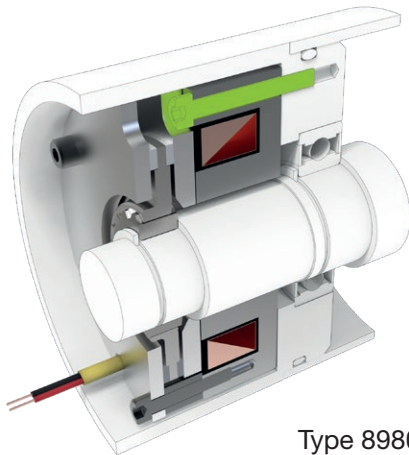

Type 8980.00100

### Screw connection on the coil carrier back side

The brakes are screwed on via threaded holes in the coil carrier and through holes, e.g., in the bearing flange (provided by the customer). The braking torque is transmitted into the hub via the tothing of the rotors. The hub must be fixed axially. Observe the installation dimensions! The braking torque is transmitted from the hub to the shaft via a key (provided by the customer).

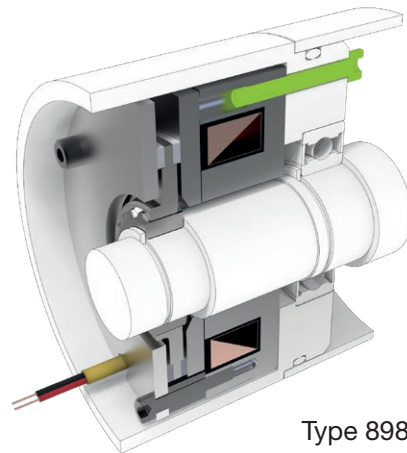

Type 8980.00000

We reserve the right to make dimensional and constructional alterations.

### Order Number

		Hub Bore with keyway	0	Operating mode Standard		0
— / 8 9 8 0 . 0 0		▼		▼		— 0 0
▲		▲		▲		
Size 50 to 160	Metal rotor with tothing		0	Screw connection		0 1
				Coil carrier back side Coil carrier front side		

Example: Order number 60 / 8980.00100

# ROBA®-servostop® Lean

## Type 8982.00101

Screw connection on the coil carrier front side

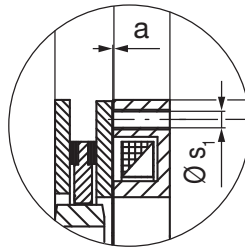

Type 8982.00001  
Screw connection on the coil carrier back side

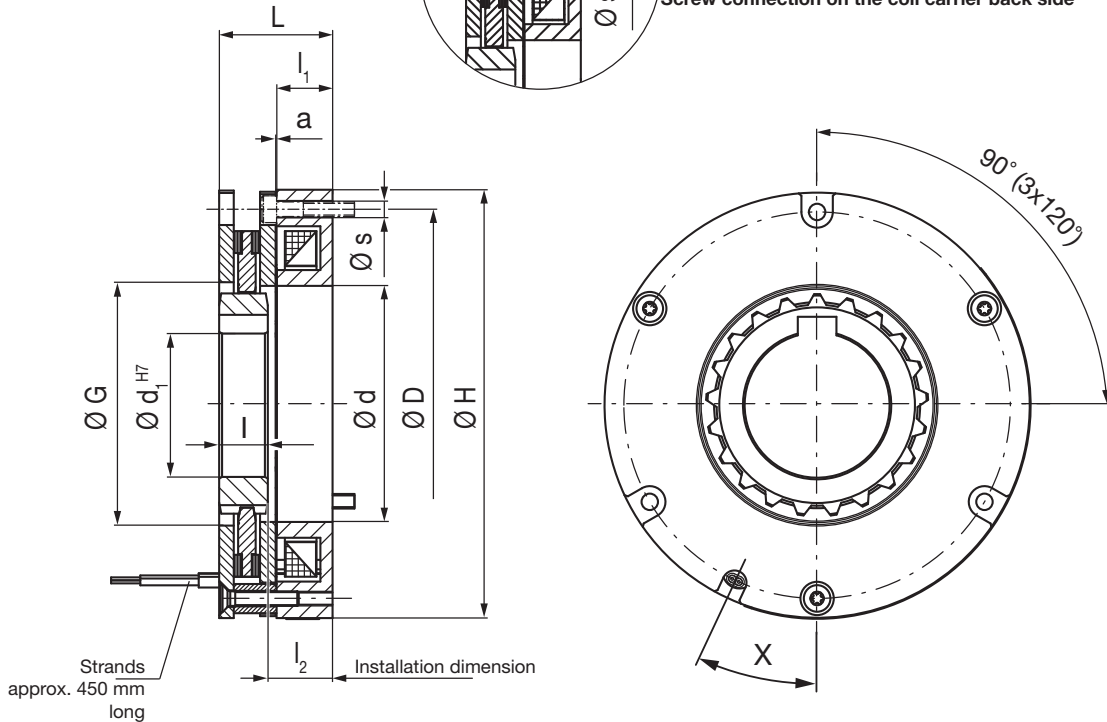

Technical Data			Size						
			40	50	60	70	80	90	100
Nominal braking torque <sup>1) 2) 3) 4)</sup>	$M_N$	[Nm]	0.31	0.7	1.9	3.7	5.5	7.9	11.5
Overexcitation voltage	$U_O$	[VDC]	24	24	24	24	24	24	24
Holding Voltage	$U_H$	[VDC]	8	8	8	8	8	8	8
Coil power at overexcitation voltage	$P_O$	[W]	20.7	28.6	42.6	53.4	60.6	71.6	83.4
Coil power at holding voltage	$P_H$	[W]	2.3	3.2	4.7	5.9	6.7	8.0	9.3
Maximum speed	$n_{max}$	[rpm]	10500	8500	7000	6500	5500	5000	4500
Max. idle speed		[rpm]	21000	16500	14000	12500	10500	10000	9000
Weight at $d_{1max}$		[kg]	0.12	0.19	0.29	0.47	0.57	0.76	0.94
Total mass moment of inertia at $d_{1max}$	$J$	[10 <sup>-6</sup> kgm <sup>2</sup> ]	1.98	7.58	16.02	21.46	44.09	83.46	135.89

Dimensions	Size						
	40	50	60	70	80	90	100
<b>a</b>	0.15	0.15	0.15	0.2	0.2	0.2	0.2
<b>d</b>	22.5	33.5	40.5	40.5	48.5	56	63
<b>d<sub>1 min</sub></b>	8	10	12	12	15	23	20
<b>d<sub>1 max</sub></b> <sup>5)</sup>	12	20	25	25	30	35	37
<b>D</b>	43	53	62	70	80	90	100
<b>G</b>	22.5	33.5	40.5	40.5	50	57	67
<b>H</b>	48	58	68	78	88	98	108
<b>L</b>	16.35	19.15	21.15	23.3	23.3	25.4	25.9
<b>l<sup>-0.2</sup></b>	7.4	9.2	9.5	9.5	10	13.5	12
<b>l<sub>1</sub></b>	8.5	10	11	11.5	11.5	11.5	12
<b>l<sub>2</sub></b> <sup>-0.5</sup>	8.95	9.95	11.65	13.8	13.3	11.9	13.9
<b>s</b>	2.4	2.4	2.9	3.4	3.4	4.5	4.5
<b>s<sub>1</sub></b>	M2,5	M2,5	M3	M4	M4	M5	M5
<b>X</b>	25°	25°	25°	25°	25°	25°	25°

We reserve the right to make dimensional and constructional alterations.

5) The respective maximum bores can be found in the table "Permitted hub bores" (page 11) according to the corresponding keyways and their tolerances.

1) Braking torque tolerance: + 75 %

2) Suitable for a temperature of 0 up to 60 °C: For higher temperatures, please consider the following braking torque reductions:  
 >60 °C to 80 °C: 10 % reduction  
 >80 °C to 100 °C: 20% reduction  
 >100 °C to 120 °C: 30% reduction

For temperature -20 °C to 0 °C:

Observe the "Ambient temperature/Climate conditions" section in the operational instructions!

3) The braking torque values are based on friction values determined in tests at *mayr*® power transmission. As a friction system is influenced by many parameters, such as mounting situation, temperature, ambient conditions, run-in condition, wear, switching work, sliding speed, aging, contamination, etc., deviating braking torques are possible. The specified nominal braking torque is a lower limit which is very likely to be reached, but cannot be guaranteed due to the many possible influences. The fluctuations in braking torques must be taken into account during dimensioning by providing appropriate safety measures. Especially for critical applications, it is important to consult *mayr*® power transmission and carry out an appropriate application check.

4) Remarks and recommendations regarding the dimensioning and selection of brakes (e.g., based on load torque and test torque) can be found in the operational instructions and may be provided on request from *mayr*® power transmission.

## ROBA®-servostop® Lean – Installation Examples

### Screw connection on the coil carrier front side

The brakes are screwed on via threaded holes in the coil carrier and through holes, e.g., in the bearing flange (provided by the customer). The braking torque is transmitted into the hub via the tothing of the rotors. The hub must be fixed axially. Observe the installation dimensions! The braking torque is transmitted from the hub to the shaft via a key (provided by the customer).

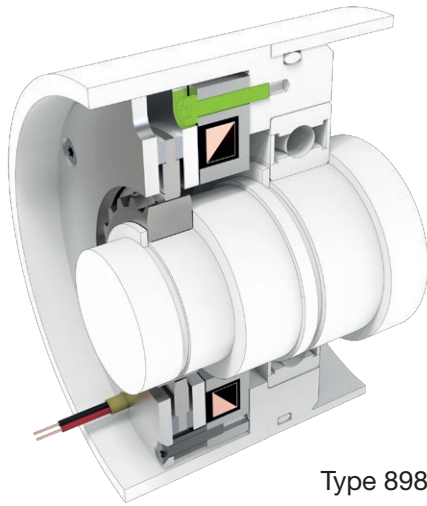

Type 8982.00101

### Screw connection on the coil carrier back side

The brakes are screwed on via threaded holes in the coil carrier and through holes, e.g., in the bearing flange (provided by the customer). The braking torque is transmitted into the hub via the tothing of the rotors. The hub must be fixed axially. Observe the installation dimensions! The braking torque is transmitted from the hub to the shaft via a key (provided by the customer).

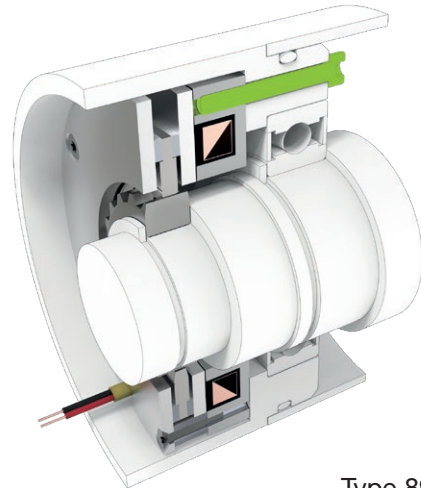

Type 8982.00001

### Order Number

										<b>Hub</b>		<b>Operating mode</b>				
										Bore with keyway		Overexcitation				
										0		1				
										▼		▼				
—	/	8	9	8	2	.	0	0	—	0	1					
▲											▲	▲				
Size 40 to 100											Metal rotor with tothing		0			
												<b>Screw connection</b>				
												0		Coil carrier back side		
												1		Coil carrier front side		

Example: Order number 60 / 8982.00101

# ROBA®-servostop® Cobot

## Type 8981.29101

Screw connection on the coil carrier front side

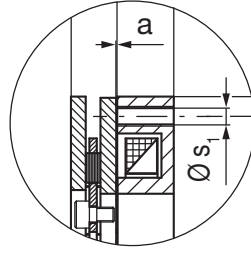
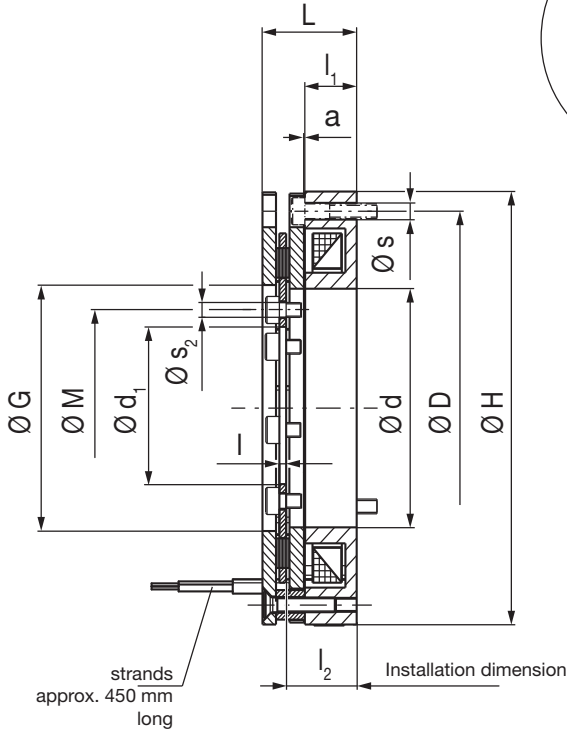

Type 8981.29001

Screw connection on the coil carrier back side

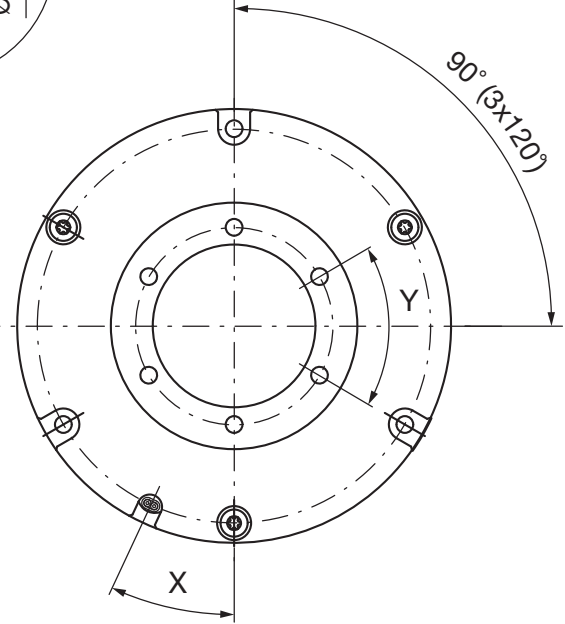

Technical Data			Size						
			40	50	60	70	80	90	100
Nominal braking torque <sup>1) 2) 3) 4)</sup>	$M_N$	[Nm]	0.23	0.5	1.4	2.7	4	6	9
Overexcitation voltage	$U_O$	[VDC]	24	24	24	24	24	24	24
Holding Voltage	$U_H$	[VDC]	8	8	8	8	8	8	8
Coil power at overexcitation voltage	$P_O$	[W]	20.7	28.6	42.6	53.4	60.6	71.6	83.4
Coil power at holding voltage	$P_H$	[W]	2.3	3.2	4.7	5.9	6.7	8.0	9.3
Maximum speed	$n_{max}$	[rpm]	10500	8500	7000	6500	5500	5000	4500
Max. idle speed		[rpm]	10500	8500	7000	6500	5500	5000	4500
Weight		[kg]	0.11	0.17	0.26	0.43	0.52	0.67	0.81
Total mass moment of inertia	J	[10 <sup>-6</sup> kgm <sup>2</sup> ]	0.75	3.12	6.13	13.73	25.61	35.99	57.08

Dimensions	Size						
	40	50	60	70	80	90	100
a	0.15	0.15	0.15	0.2	0.2	0.2	0.2
d	22.5	33.5	40.5	40.5	48.5	56	63
$d_{1+0.1}$	13	22	29	29	33	40	47
D	43	53	62	70	80	90	100
G	22.5	33.5	40.5	40.5	50	57	67
H	48	58	68	78	88	98	108
L	13.35	16.35	18.35	20.9	20.9	21.9	22.4
I	0.6	1	1	1.5	1.5	1.5	1.5
$I_1$	8.5	10	11	11.5	11.5	11.5	12
$I_2$	10.8 ±0.1	12.85 ±0.1	14.35 ±0.1	15.65 ±0.2	15.65 ±0.2	16.15 ±0.2	16.65 ±0.2
M	17	27	34	34	40	47	54
s	2.4	2.4	2.9	3.4	3.4	4.5	4.5
$s_1$	M2,5	M2,5	M3	M4	M4	M5	M5
$s_2$	1.8	2.4	2.4	2.4	3.4	3.4	3.4
X	25°	25°	25°	25°	25°	25°	25°
Y	90° (4x)	90° (4x)	60° (6x)	36° (10x)	60° (6x)	45° (8x)	36° (10x)

1) Braking torque tolerance: + 75 %

2) Suitable for a temperature of 0 up to 60 °C: For higher temperatures, please consider the following braking torque reductions:  
 >60 °C to 80 °C: 10 % reduction  
 >80 °C to 100 °C: 20% reduction  
 >100 °C to 120 °C: 30% reduction

For temperature -20 °C to 0 °C:

Observe the "Ambient temperature/Climat conditions" section in the operational instructions!

3) The braking torque values are based on friction values determined in tests at mayr® power transmission. As a friction system is influenced by many parameters, such as mounting situation, temperature, ambient conditions, run-in condition, wear, switching work, sliding speed, aging, contamination, etc., deviating braking torques are possible. The specified nominal braking torque is a lower limit which is very likely to be reached, but cannot be guaranteed due to the many possible influences. The fluctuations in braking torques must be taken into account during dimensioning by providing appropriate safety measures. Especially for critical applications, it is important to consult mayr® power transmission and carry out an appropriate application check.

We reserve the right to make dimensional and constructional alterations.

4) Remarks and recommendations regarding the dimensioning and selection of brakes (e.g., based on load torque and test torque) can be found in the operational instructions and may be provided on request from mayr® power transmission.

## ROBA<sup>®</sup>-servostop<sup>®</sup> Cobot – Installation Examples

### Screw connection on the coil carrier front side

The brakes are screwed on via threaded holes in the coil carrier with through holes, e.g., in the bearing flange (provided by the customer). The rotor disk with the friction lining pads is screwed to the collar of the stepped shaft or hollow shaft (provided by the customers). Observe the installation dimensions!

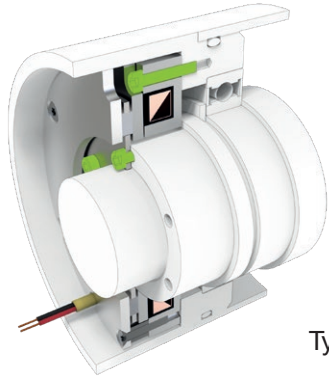

Type 8981.29101

### Screw connection on the coil carrier back side

The brake is mounted via through holes, e.g., in the bearing shield (provided by the customer) and threaded holes in the coil carrier rear side. The rotor disk with the friction lining pads is screwed to the collar of the stepped shaft or hollow shaft (provided by the customers). Observe the installation dimensions!

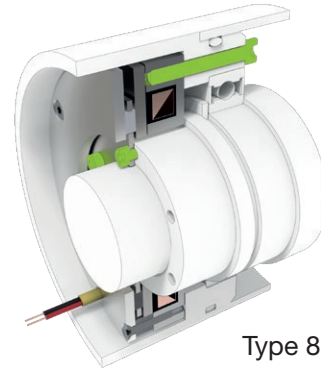

Type 8981.29001

### Screw connection via the flange plate (special design)

Customer-specific installation situation The brakes are screwed on via threaded holes in the flange plate and through holes, e.g., in the bearing flange (provided by the customer). The rotor disk with the friction lining pads is screwed to the shaft / hollow shaft front side. Observe the installation dimensions!

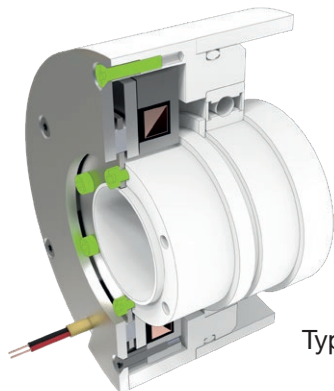

Type 8981.29201 S

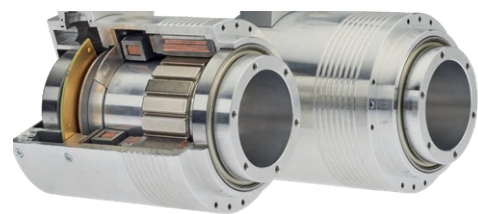

© TQ-Systems GmbH

### Order Number

		Hub		Operating mode	
		Without hub	9	Overexcitation	1
		▼		▼	
_	/ 8	9	8	1	. 2
		▲		▲	
_				0	1
		▲		▲	
Size 40 to 100	Rotor disk			2	<b>Screw connection</b>
				0	Coil carrier back side
				1	Coil carrier front side

Example: Order number 60 / 8981.29101

Switching Times			Type 8980.00_00								Type 8982.00_01						Type 8981.29_01								
			Size	50	60	70	80	90	100	120	140	160	40	50	60	70	80	90	100	40	50	60	70	80	90
Connection time	DC-side switching	$t_1$ [ms]	55	55	55	55	65	70	80	90	90	15	15	15	20	20	30	30	15	15	15	20	20	30	30
	AC-side switching	$t_1$ [ms]	340	360	370	370	410	440	570	590	590	65	65	65	80	90	150	150	65	65	65	80	90	150	150
Response delay on connection	DC-side switching	$t_{11}$ [ms]	45	45	45	35	40	45	50	55	55	10	10	10	15	15	20	20	10	10	10	15	15	20	20
	AC-side switching	$t_{11}$ [ms]	230	250	260	260	280	300	390	400	400	50	50	50	60	60	100	100	50	50	50	60	60	100	100
Separation time (release)		$t_2$ [ms]	70	75	100	125	150	175	250	300	440	25	25	35	50	70	70	70	25	25	35	50	70	70	70

Friction work Classic		Size								
		50	60	70	80	90	100	120	140	160
max. friction work on individual switching (1...10 switchings in a succession)	[J]	300	325	375	550	900	950	1500	2100	3500
Dynamic braking torque restrictions ( $M_{dyn-min}$ ) in the speed range										
$M_{dyn-min} = M_N$	n [rpm]	0 - 5000	0 - 4000	0 - 3600	0 - 3200	0 - 3000	0 - 2500	0 - 2000	0 - 1700	0 - 1500
$M_{dyn-min} = M_N - 15\%$	n [rpm]	5000 - 7500	4000 - 6200	3600 - 5500	3200 - 4700	3000 - 4300	2500 - 3600	2000 - 2900	1700 - 2500	1500 - 2200
$M_{dyn-min} = M_N - 30\%$	n [rpm]	7500 - 9500	6200 - 8000	5500 - 7000	4700 - 6500	4300 - 5500	3600 - 5000	2900 - 4000	2500 - 3500	2200 - 3000
Wear restriction (max. number of individual braking actions at max. friction work in the speed range)										
2000	n [rpm]	0 - 5000	0 - 4000	0 - 3600	0 - 3200	0 - 3000	0 - 2500	0 - 2000	0 - 1700	0 - 1500
1400	n [rpm]	5000 - 7500	4000 - 6200	3600 - 5500	3200 - 4700	3000 - 4300	2500 - 3600	2000 - 2900	1700 - 2500	1500 - 2200
1000	n [rpm]	7500 - 9500	6200 - 8000	5500 - 7000	4700 - 6500	4300 - 5500	3600 - 5000	2900 - 4000	2500 - 3500	2200 - 3000

Friction work Lean		Size						
		40	50	60	70	80	90	100
max. friction work on individual switching (1...10 switchings in a succession)	[J]	150	200	230	550	650	850	1000
Dynamic braking torque restrictions ( $M_{dyn-min}$ ) in the speed range								
$M_{dyn-min} = M_N$	n [rpm]	0 - 5000	0 - 4000	0 - 3500	0 - 3000	0 - 2500	0 - 2500	0 - 2000
$M_{dyn-min} = M_N - 15\%$	n [rpm]	5000 - 8000	4000 - 6000	3500 - 5000	3000 - 4500	2500 - 4000	2500 - 3500	2000 - 3500
$M_{dyn-min} = M_N - 30\%$	n [rpm]	8000 - 10500	6000 - 8500	5000 - 7000	4500 - 6500	4000 - 5500	3500 - 5000	3500 - 4500
Wear restriction (max. number of individual braking actions at max. friction work in the speed range)								
2000	n [rpm]	0 - 5000	0 - 4000	0 - 3500	0 - 3000	0 - 2500	0 - 2500	0 - 2000
1400	n [rpm]	5000 - 8000	4000 - 6000	3500 - 5000	3000 - 4500	2500 - 4000	2500 - 3500	2000 - 3500
1000	n [rpm]	8000 - 10500	6000 - 8500	5000 - 7000	4500 - 6500	4000 - 5500	3500 - 5000	3500 - 4500

Friction work Cobot		Size						
		40	50	60	70	80	90	100
max. friction work on individual switching (1...10 switchings in a succession)	[J]	25	50	80	175	200	250	350
Dynamic braking torque restrictions ( $M_{dyn-min}$ ) in the speed range								
$M_{dyn-min} = M_N$	n [rpm]	0 - 5000	0 - 4000	0 - 3500	0 - 3000	0 - 2500	0 - 2500	0 - 2000
$M_{dyn-min} = M_N - 15\%$	n [rpm]	5000 - 8000	4000 - 6000	3500 - 5000	3000 - 4500	2500 - 4000	2500 - 3500	2000 - 3500
$M_{dyn-min} = M_N - 30\%$	n [rpm]	8000 - 10500	6000 - 8500	5000 - 7000	4500 - 6500	4000 - 5500	3500 - 5000	3500 - 4500
Wear restriction (max. number of individual braking actions at max. friction work in the speed range)								
1000	n [rpm]	0 - 5000	0 - 4000	0 - 3500	0 - 3000	0 - 2500	0 - 2500	0 - 2000
700	n [rpm]	5000 - 8000	4000 - 6000	3500 - 5000	3000 - 4500	2500 - 4000	2500 - 3500	2000 - 3500
500	n [rpm]	8000 - 10500	6000 - 8500	5000 - 7000	4500 - 6500	4000 - 5500	3500 - 5000	3500 - 4500

Permitted Hub Bores $\varnothing d_{1 \max}$				Size									
				40	50	60	70	80	90	100	120	140	160
Type 8980.00_00	Keyway JS9	6885/1	[mm]	-	11	13	18	18	22	30	32	42	45
		6885/2	[mm]	-	12	-	-	-	-	-	-	-	-
		6885/3	[mm]	-	-	15	20	20	25	-	35	45	50
Type 8982.00_01	Keyway JS9	6885/1	[mm]	11	18	22	22	30	32	37	-	-	-
		6885/2	[mm]	12	-	-	-	-	-	-	-	-	-
		6885/3	[mm]	-	20	25	25	-	35	-	-	-	-

**Keys**

$M_{br}$  = Braking torque

$M_L$  = Load torque

$t_1$  = Connection time

$t_{11}$  = Response delay on connection

$t_2$  = Separation time

$t_o$  = Overexcitation time

$U_H$  = Holding voltage

$U_N$  = Coil nominal voltage

$U_o$  = Overexcitation voltage

## Headquarters

Chr. Mayr GmbH + Co. KG  
Eichenstraße 1, D-87665 Mauerstetten  
Tel.: +49 83 41/8 04-0, Fax: +49 83 41/80 44 21  
www.mayr.com, E-Mail: public.mayr@mayr.com



## Service Germany/Austria

### Baden-Württemberg

Esslinger Straße 7  
70771 Leinfelden-Echterdingen  
Tel.: 07 11/78 26 26 40  
Fax: 07 11/78 26 26 39

### Bavaria

Industriestraße 51  
82194 Gröbenzell  
Tel.: 0 81 42/50 19 808

### Chemnitz

Bornaer Straße 205  
09114 Chemnitz  
Tel.: 03 71/4 74 18 96  
Fax: 03 71/4 74 18 95

### Franken

Unterer Markt 9  
91217 Hersbruck  
Tel.: 0 91 51/81 48 64  
Fax: 0 91 51/81 62 45

### Kamen

Herbert-Wehner-Straße 2  
59174 Kamen  
Tel.: 0 23 07/24 26 79  
Fax: 0 23 07/24 26 74

### North

Schiefer Brink 8  
32699 Extertal  
Tel.: 0 57 54/9 20 77  
Fax: 0 57 54/9 20 78

### Rhine-Main

Kohlhäuser Str. 3-5  
36043 Fulda  
Tel.: 06 61/96 21 02 15

### Austria

Pummerinplatz 1, TIZ I, A27  
4490 St. Florian, Austria  
Tel.: 0 72 24/2 20 81-12  
Fax: 0 72 24/2 20 81 89

## Branch office

### China

Mayr Zhangjiagang  
Power Transmission Co., Ltd.  
Fuxin Road No.1298, Yangshe Town  
215637 Zhangjiagang  
Tel.: 05 12/58 91-75 67  
Fax: 05 12/58 91-75 66  
info@mayr-ptc.cn

### France

Mayr France S.A.S.  
Z.A.L. du Minopole  
Rue Nungesser et Coli  
62160 Bully-Les-Mines  
Tel.: 03.21.72.91.91  
Fax: 03.21.29.71.77  
contact@mayr.fr

### Great Britain

Mayr Transmissions Ltd.  
Valley Road, Business Park  
Keighley, BD21 4LZ  
West Yorkshire  
Tel.: 0 15 35/66 39 00  
Fax: 0 15 35/66 32 61  
sales@mayr.co.uk

### Italy

Mayr Italia S.r.l.  
Viale Veneto, 3  
35020 Saonara (PD)  
Tel.: 049/879 10 20  
Fax: 049/879 10 22  
info@mayr-italia.it

### Japan

Mayr Japan LLC  
2F, 1-1-9 Nihonbashi Kakigara-cho,  
Chuo-ku Tokyo, 103-0014 Japan  
Tel.: 03/35 27-29 00  
Fax: 03/35 27-26 61  
public.mayr@mayr.co.jp

### Singapore

Mayr Transmission (S) PTE Ltd.  
No. 8 Boon Lay Way Unit 03-06,  
TradeHub 21  
Singapore 609964  
Tel.: 00 65/65 60 12 30  
Fax: 00 65/65 60 10 00  
info@mayr.com.sg

### Switzerland

Mayr Kupplungen AG  
Tobeläckerstraße 11  
8212 Neuhausen am Rheinflall  
Tel.: 0 52/6 74 08 70  
Fax: 0 52/6 74 08 75  
info@mayr.ch

### USA

Mayr Corporation  
10 Industrial Avenue  
Mahwah  
NJ 07430  
Tel.: 2 01/4 45-72 10  
Fax: 2 01/4 45-80 19  
info@mayrcorp.com

## Representatives

### Australia

Drive Systems Pty Ltd.  
8/32 Melverton Drive  
Hallam, Victoria 3803  
Australien  
Tel.: 0 3/97 96 48 00  
info@drivesystems.com.au

### India

National Engineering  
Company (NENCO)  
J-225, M.I.D.C.  
Bhosari Pune 411026  
Tel.: 0 20/27 13 00 29  
Fax: 0 20/27 13 02 29  
nenco@nenco.org

### Netherlands

Groneman BV  
Amarilstraat 11  
7554 TV Hengelo OV  
Tel.: 074/2 55 11 40  
Fax: 074/2 55 11 09  
aandrijftechniek@groneman.nl

### Poland

Wamex Sp. z o.o.  
ul. Pozaryskiego, 28  
04-703 Warszawa  
Tel.: 0 22/6 15 90 80  
Fax: 0 22/8 15 61 80  
wamex@wamex.com.pl

### South Korea

Mayr Korea Co. Ltd.  
15, Yeondeok-ro 9beon-gil  
Seongsan-gu  
51571 Changwon-si  
Gyeongsangnam-do. Korea  
Tel.: 0 55/2 62-40 24  
Fax: 0 55/2 62-40 25  
info@mayrkorea.com

### Taiwan

German Tech  
Component Co., Ltd.  
No.10-3, Ln. 358, Sec. 1,  
Hemu Rd., Shengang Dist.,  
429012 Taichung City  
Tel.: +886 (4) 25150566  
Fax: +886 (4) 25152413  
abby@zfgta.com.tw

### Czech Republic

BMC - TECH s.r.o.  
Hviezdoslavova 29 b  
62700 Brno  
Tel.: 05/45 22 60 47  
Fax: 05/45 22 60 48  
info@bmc-tech.cz

### Turkey

Representative Office Turkey  
Kucukbakkalkoy Mah.  
Brandium Residence R2  
Blok D:254  
34750 Atasehir - Istanbul, Turkey  
Tel.: 02 16/2 32 20 44  
Fax: 02 16/5 04 41 72  
info@mayr.com.tr

## More representatives:

Belgium, Brazil, Canada, Colombia, Croatia, Denmark, Finland, Greece, Hongkong, Hungary, Indonesia, Israel, Luxembourg, Malaysia, Mexico, New Zealand, Norway, Philippines, Portugal, Romania, Russia, Slovakia, Slovenia, South Africa, Spain, Sweden, Thailand

You can find the complete contact details for the representative responsible for your area in the Contact section at [www.mayr.com](http://www.mayr.com)

