

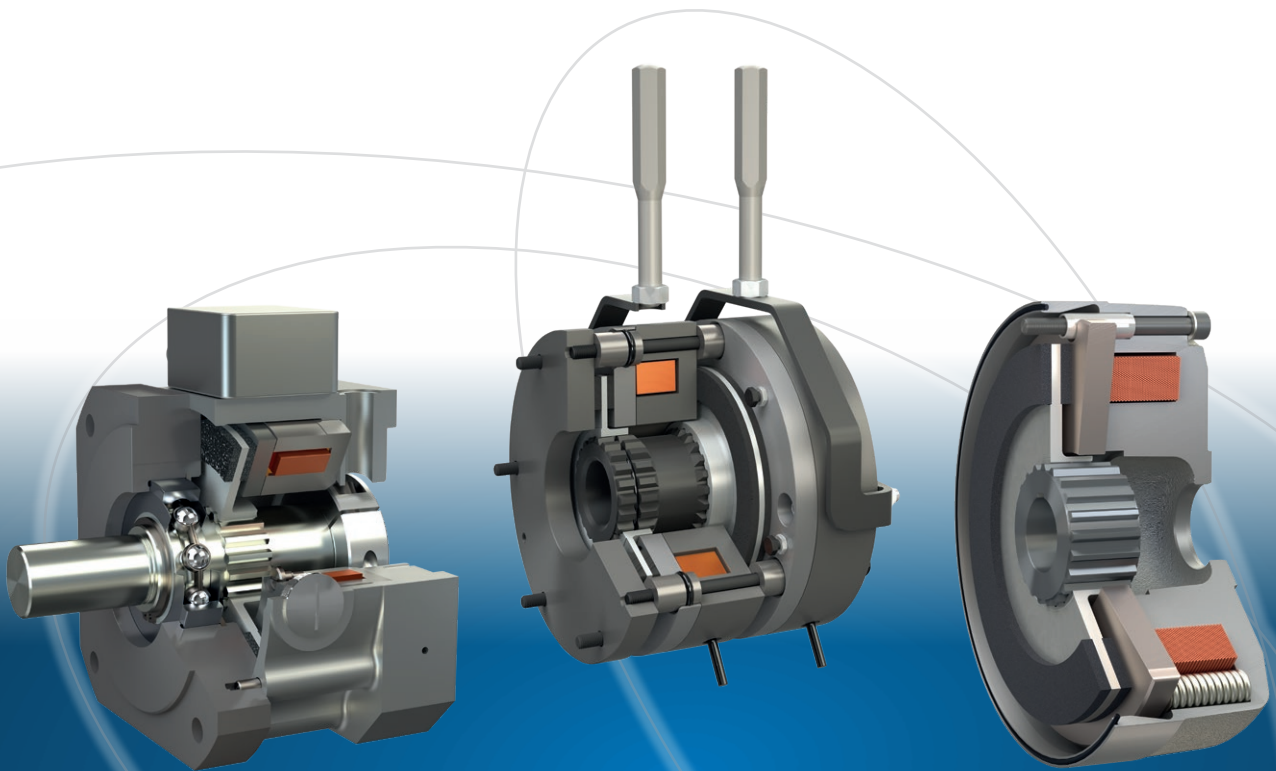

your reliable partner



Safety Brakes

We safeguard the movements of this world



The Christian Mayr mill-construction business – founded in 1897.



Communications Centre mayr.com – opened in 2018.

Specialists in power transmission for more than a century

mayr[®] power transmission is one of the most traditional and yet most innovative German companies in the field of power transmission. From modest beginnings in the year 1897, the family enterprise from the Allgäu region has developed into the world market leader. Today, approximately 700 employees work at the headquarters in Mauerstetten; about 1200 employees work for the company worldwide.

An unsurpassed standard product range

mayr[®] power transmission offers a wide variety of torque limiters, safety brakes, backlash-free shaft misalignment compensation couplings and high-quality DC drives. Regarding customer-specific requirements, too, the company possesses the expertise to develop customized and economical solutions. This is why numerous renowned machine manufacturers trust in holistic solutions by *mayr*[®] power transmission.

Represented worldwide

With eight subsidiaries in Germany, sales offices in the USA, France, Great Britain, Italy, Singapore and Switzerland as well as 36 additional country representatives, *mayr*[®] is available in all important industrial areas, guaranteeing optimum customer service around the globe.



Tradition and innovation – the best of both worlds

Tradition and innovation do not contradict each other - on the contrary. They are the two supporting pillars which have guaranteed stability and reliability for generations. Long-term stability, independence as well as a good reputation and satisfied customers are important values for a family enterprise rich in tradition.

Therefore, we place emphasis on:

- Tested product quality,
- Optimum customer service,
- Comprehensive know-how,
- Global presence,
- Successful innovations and
- Effective cost management.

By pursuing our own objective of always offering our customers the technologically most advanced and most economical solution, we have been able to gain the trust of many leading industrial companies from all branches and from all over the world as a reliable partner.

Place your trust in our know-how and our more than 50 years of experience in torque limiters, safety brakes and shaft couplings.

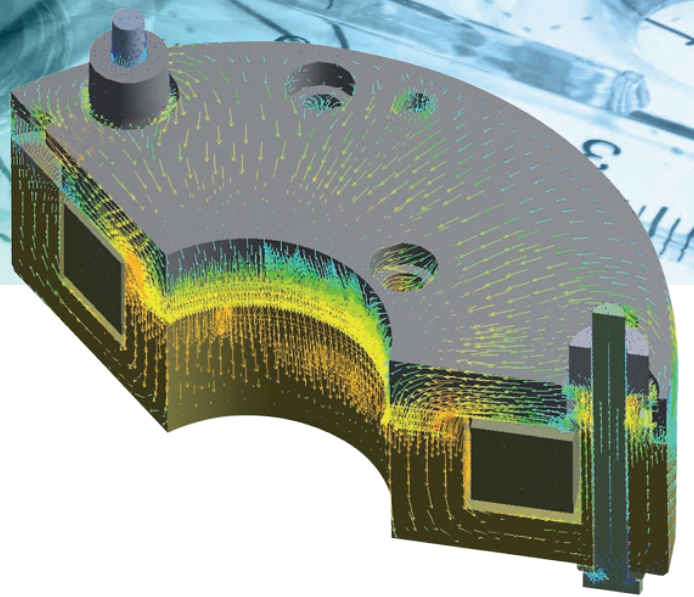



Tested quality and reliability

mayr® products are subject to meticulous quality inspections. These include quality assurance measures during the design process as well as a comprehensive final inspection. Only the best, tested quality leaves our place of manufacture. All products are rigorously tested on calibrated test stands, and adjusted precisely to the requested values. An electronic database in which the measurement values are archived together with the associated serial numbers guarantees 100 % traceability. On request, we confirm the product characteristics with a test protocol.

The certification of our quality management according to DIN EN ISO 9001:2015 confirms the quality-consciousness of our colleagues at every level of the company.

Never compromise on safety

We make no compromises where safety is concerned. Only top products of a perfect quality guarantee that no people are injured or machines damaged in case of malfunctions, collisions and other hazardous situations. The safety of your employees and machines is our motivation to always provide the best and most reliable clutches, couplings or brakes.

mayr® power transmission holds numerous ground-breaking patents, and is the global market or technological leader for

- application-optimised **safety brakes**, for example for passenger elevators, stage technology and gravity-loaded axes
- **torque limiters** to protect against expensive overload damage and production losses and
- backlash-free **servo couplings**.

Function

ROBA-stop® safety brakes are spring applied, electromagnetic safety brakes. These brakes ensure reliable and safe braking of machines and systems in any position in the event of a power switch-off, a power failure or an EMERGENCY STOP.



On request ROBA-stop® safety brakes can also be delivered with UL approval.

Overview

[Brake description page ...](#)

- Construction Types we recommend
- Suitable Types

Exemplary application areas

	6	6	7	8	9	10	11	12	13	14	14	14	15	16	17	18	19	20	20	20	20	21	
ROBA-stop®-M-positioning brake																							
ROBA-stop®-M-holding brake																							
ROBA®-topstop®																							
ROBA®-alphastop®																							
ROBA®-servostop®																							
ROBA®-servostop® for Robotics																							
ROBA®-pinionstop																							
ROBA®-linearstop																							
ROBA®-guidestop																							
ROBA-stop®-silenzio® dual circuit brake																							
ROBA-stop®-silenzio® single circuit brake																							
ROBA-stop®-silenzio® with double rotor																							
ROBA®-diskstop®																							
ROBA®-duplostop®																							
ROBA®-twinstop®																							
ROBA®-quatrostop																							
ROBA-stop®-stage																							
ROBA-stop®- positioning brake																							
ROBA-stop®-holding brake																							
ROBA-stop® - tachometer brake																							
ROBA-stop® - peak load brake																							
ROBA-stop®-S																							
General mechanical engineering																							
Electromotors																							
Servo drives																							
Crane construction																							
Harbour/ship/seawater																							
Elevator construction																							
Escalators																							
Stage construction																							
Hoists																							
Mobile devices with low voltage																							
Medical technology																							
Robots/handling																							
Gravity loaded axes																							
Linear motors																							
Machine tools																							

Special characteristics

CSA-certification																							
ATEX design																							
Sealed design																							
Two independent brake circuits																							
Minimal noise																							
Brake description page ...	6	6	7	8	9	10	11	12	13	14	14	14	15	16	17	18	19	20	20	20	20	21	

ROBA-stop[®]-M

The robust, cost-effective motor brake

Performance Characteristics

- **Maintenance-free (no re-adjustment)**
- **Simple installation**
- **Completely enclosed brake housing acc. Protection IP54 or IP66**
- **Class of insulation F**
- **Can be used for 100 % duty cycle**
- **Short switching times**

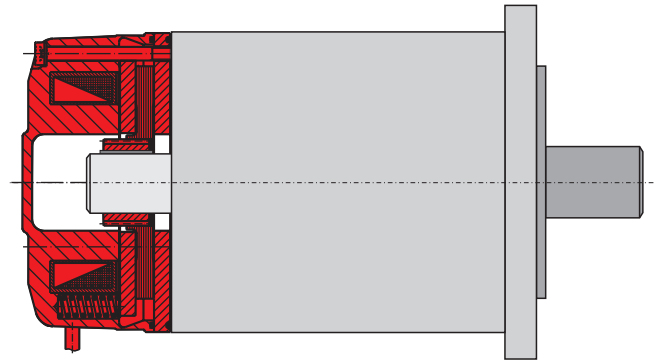

ROBA-stop[®]-M safety brake on the B-bearing side of an electromotor. The design with flange plate is used if there is no suitable counterfriction surface for the brake linings available motor-side.



Designs

- ROBA-stop[®]-standard brake**
Is suitable for high friction work
As a dynamic brake it brakes from movement
- ROBA-stop[®]-M holding brake**
Holds drives safely in position when they are not running and brakes from movement on EMERGENCY STOP.

Technical Data, Dimensions				Size										
				2	4	8	16	32	60	100	150	250	500	1000
Braking torque ¹⁾	Standard brake	M	[Nm]	2	4	8	16	32	60	100	150	250	500	1000
	Holding brake	M	[Nm]	4	8	16	32	64	100	180	280	460	900	1800
Shaft Ø	Standard brake		[mm]	8 – 15	10 – 15	11 – 20	14 – 25	19 – 30	22 – 35	24 – 45	30 – 50	40 – 60	50 – 80	75 – 90
	Holding brake		[mm]	8 – 15	10 – 15	11 – 20	14 – 25	19 – 30	22 – 35	24 – 45	30 – 50	40 – 55	52 – 75	75 – 90
Brake	Outer Ø	D	[mm]	76	87	103	128	148	168	200	221	258	310	382
	Length	L	[mm]	39	41.5	45.2	55.7	61.7	72.5	84	97	116	114	135

1) Tolerance +40 % / -20 %

ROBA®-topstop® Modular safety brake system for a servomotor attachment on the A-bearing side

Performance Characteristics

- The axis is held safely in any position, even with a dismantled servomotor, e.g. during machine maintenance
- Optimum braking system for vertical axes and when handling large weights
- Long lifetime even after frequent EMERGENCY STOP brakings
- Indication of the operating condition (opened/closed) via an integrated condition monitoring
- Short, compact design
- Low rotatory moments of inertia
- Low self-induced heat production even at 100 % duty cycle
- Design with Protection IP65 available

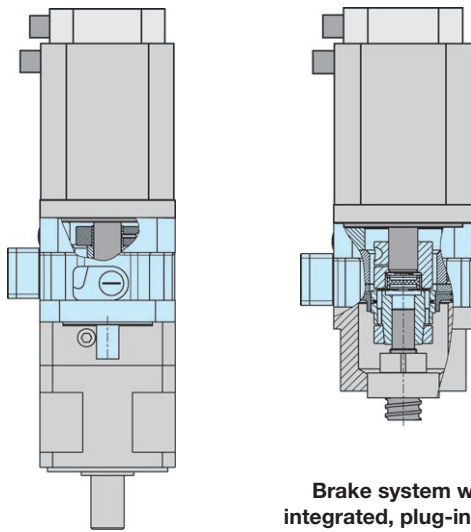
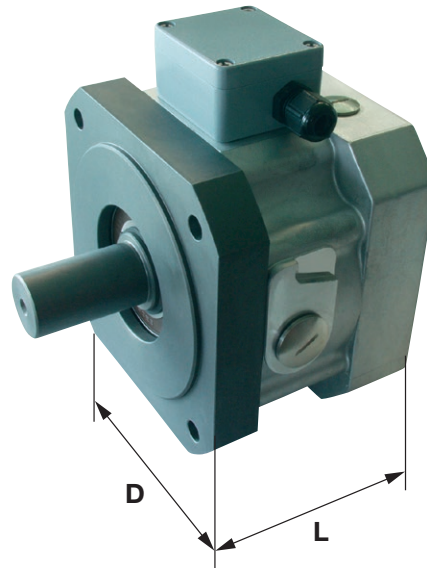

ROBA®-topstop® with output shaft for direct mounting onto a gearbox with a hollow shaft.

Brake system with integrated, plug-in shaft coupling. Separate coupling and coupling housing are no longer necessary. Very short design.

Designs

- Single circuit brake with a bearing-supported output shaft: i.e. suitable for toothed belt drives
- Single circuit brake with an integrated plug-in shaft coupling
- Single circuit brake with a shaft coupling and an installed EAS®-smartic® torque limiter
- Redundant dual circuit brake system with a bearing-supported output shaft
- Basic brake module for special brake configurations

Due to their adaptable flange dimensions, ROBA®-topstop® safety brakes can easily be integrated into pre-existing constructions between the servomotor and the counterflange. If necessary, the design can be easily adapted to any installation situation by changing the standard flanges. Seven standard sizes for braking torques of 6 to 400 Nm are available for delivery at short notice.

Technical Data, Dimensions				Size						
				100	120	150	175	200	230	260
Braking torque ¹⁾	Single circuit brake	M	[Nm]	6	12	45	70	100	150	200
	Single circuit brake (with overexcitation)	M	[Nm]	12	30	90	120	160	300	400
Single circuit brake	4-cornered flange	D	[mm]	100	126	155	176	194	235	264
	Length	L	[mm]	80	104	119	138.5	138.5	185	185

1) Tolerance +40 % / -20 %

ROBA[®]-topstop[®] Brake module with plug-in shaft coupling

These brake modules were conceived for special customer-specific applications. Depending on the respective mounting situation, these brake can be mounted directly onto a pre-installed friction flange, or they can be delivered with a mounting flange which has been specially adapted for the particular application.

The brake module can be equipped with the standard clamping hub shaft and ROBA[®]-ES shaft couplings or with special coupling constructions which can be optimally adapted for individual mounting conditions.

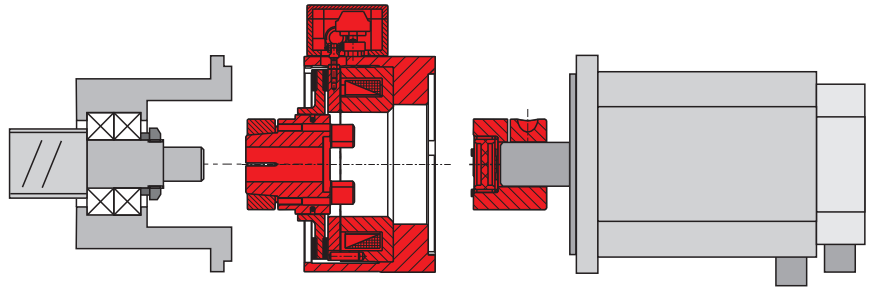

ROBA[®]-alphastop[®] Safety brake for A-bearing-side attachment onto Fanuc motors

Performance Characteristics

- Complete unit with backlash-free shaft coupling
- Easy installation between servomotor and mounting flange
- Completely enclosed brake housing
- Design with output shaft for direct installation onto hollow shaft gearboxes
- Can be used for 100 % duty cycle



The ROBA[®]-alphastop[®] is a safety brake, installed between the servomotor and a bell housing. The brake toothed hub is combined with the smartflex[®] backlash-free steel bellows coupling. Frictionally-locking clamping rings ensure backlash-free torque transmission between the motor and the ball screw spindle.

The ROBA[®]-alphastop[®] is designed with an output shaft for direct mounting onto a gearbox with a hollow shaft, meaning that the shaft coupling is unnecessary.

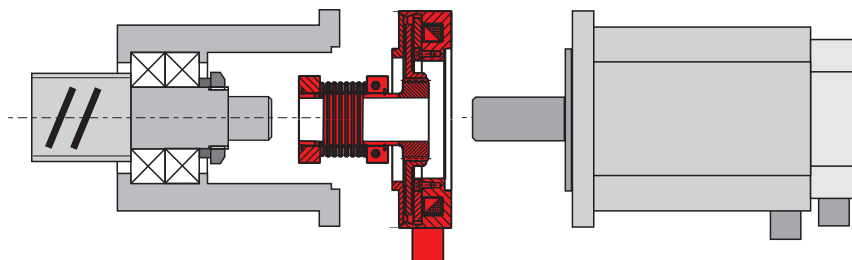

ROBA®-servostop®

The perfect safety brake for servo motors

Performance Characteristics

- Can be used up to 120 °C
- High permitted friction work
- High performance density
- Low mass moment of inertia
- Axial positioning to shaft not required
- Reliable due to fail-safe principle
- High operational safety
- Simple and robust design
- Simple installation

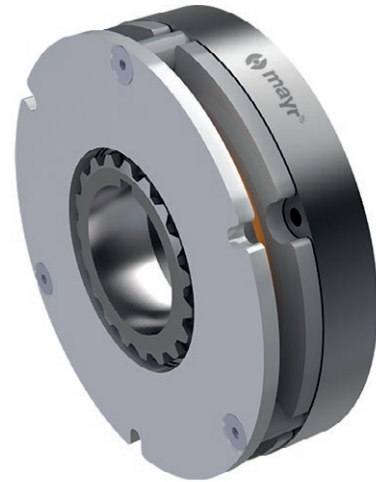

Installation Example

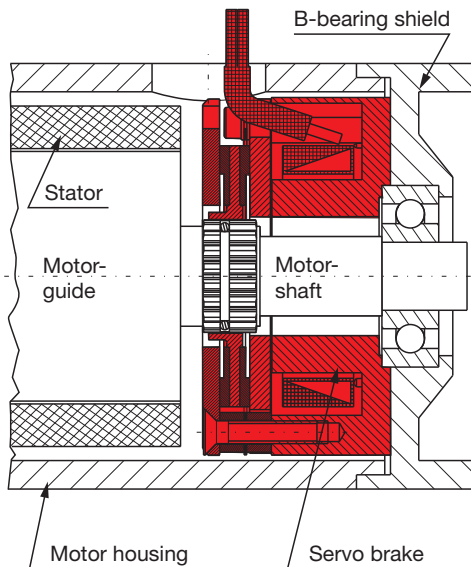

Optimally tailored to your servomotors

We will design a perfectly adapted and aligned solution suitable for your servomotors. Just contact us!

The table below contains only the most important data and dimensions of the basic sizes.

ROBA®-servostop® in the B-bearing shield of a motor:
 Due to their special construction, temperature-induced expansion and bearing backlash have no negative influence on the brake function and reliability.

Technical Data, Dimensions			Size					
			60	80	100	120	140	160
Minimum holding torque at an ambient temperature of 120 °C	M_N	[Nm]	3.25	7	16	32	60	100
Outer Ø	D	[mm]	62	80	102	124	147	166
Length	L	[mm]	30	36	45	45.6	54.6	60.6

ROBA[®]-servostop[®] for robotic applications

Robust lightweight brakes for demanding operating conditions

Performance Characteristics

- **Extremely thin and lightweight construction shape**
- High performance density in spite of low energy intake
- Adapted geometry for very different installation situations
- Extremely short switching times
- Can be used up to 120 °C
- Ready for installation
- Inspected unit
- Can be produced with a large inner diameter, for example for use in hollow shaft motors

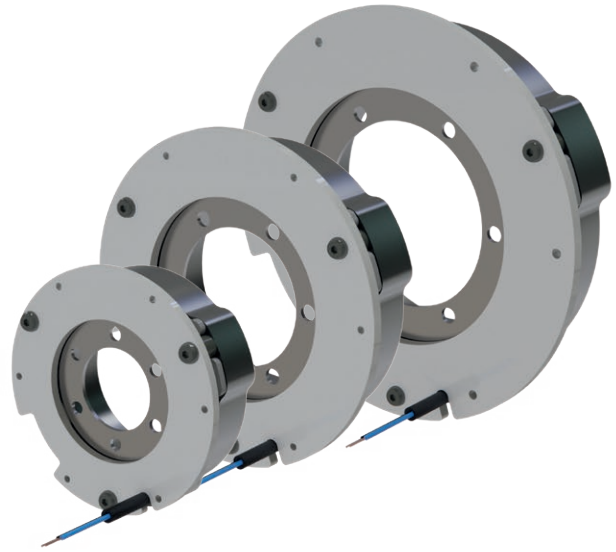

The ROBA[®]-servostop[®] safety brakes are tailored to robotic requirements with their extremely thin construction shape and low weight, and can therefore easily cope in demanding operating conditions. They guarantee reliable, constant holding torques over the entire service lifetime, have a high performance density and are wear-resistant.

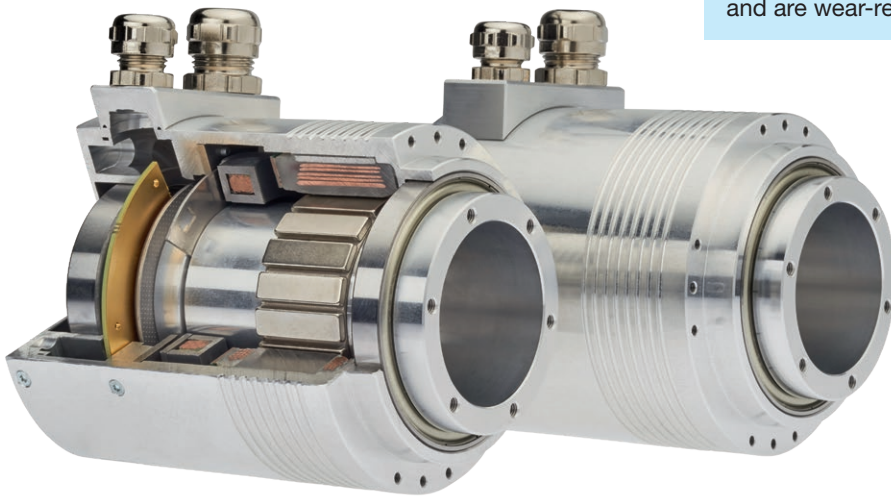

ROBA[®]-servostop[®] safety brakes in the compact RoboDrive hollow shaft motors of the RD construction series. Fig: TQ-Systems GmbH

Technical Data, Dimensions			Size								
			50		60		80		100		
Nominal braking torque	M _N	[Nm]	0.18	0.3	0.6	0.84	1.44	1.68	3.12	6.8	13.4
Outer Ø	D	[mm]	53.4		72.4		88.4		118.4		
Length	L	[mm]	15.85		17.9		17.9		25.95		

ROBA[®]-pinionstop The safe rack and pinion brake

Performance Characteristics

- Safe holding of the axis via ready-to-install brake module with pinion shaft
- Independent, electromagnetically releasing spring applied brake system
- Integrated release monitoring
- Sealed brake housing
- Individual dimensioning and design possibilities of the brake configuration
- Simple installation
- Easy implementation of a redundant brake system (according to category 3) by mounting a second ROBA[®]-pinionstop brake or by using an additional brake on the servomotor.



The ROBA[®]-pinionstop as an independent brake system engages directly and in any position onto the toothed rack and is closed in a de-energized condition. This safety brake is therefore able to offer high safety on power failure and EMERGENCY STOP as well as during installation and maintenance work.

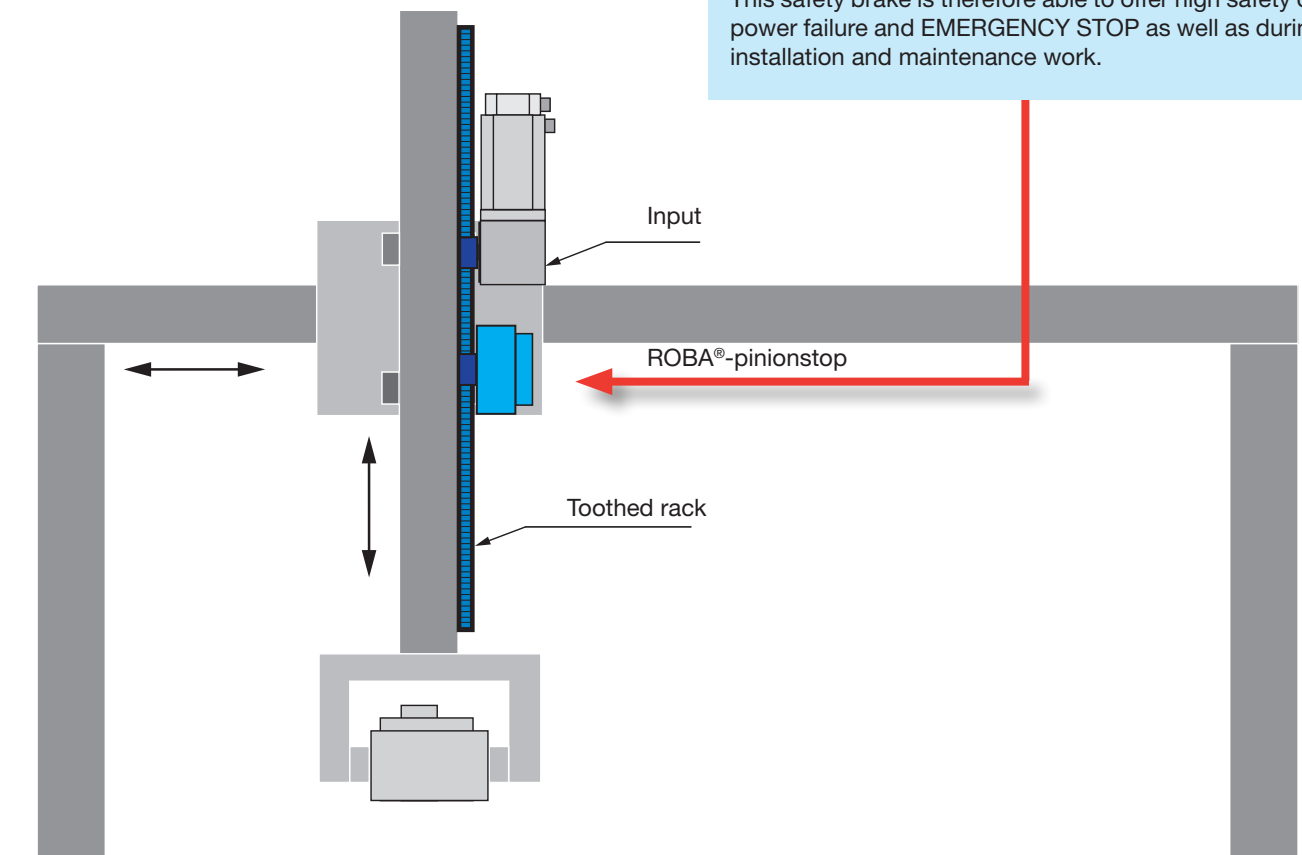

ROBA®-linearstop

The hydraulic, pneumatic and electromagnetic brake system for linear axes

Performance Characteristics

- Backlash-free force transmission having an effect on both sides
- Safety brake system according to the fail-safe principle
- No self-reinforcement during clamping
- Clearing the clamping device is not necessary
- Maximum performance density
- Suitable for EMERGENCY STOP braking actions
- Minimum reaction times
- Integrated switching condition monitoring possible
- Long service lifetime
- Can easily be integrated into existing constructions
- TÜV (German Technical Inspectorate) -tested acc. Trade Association inspection policies (not valid for Type 382)

Additionally on pneumatic design Type 381.1_ _0

- Reliable dynamic braking

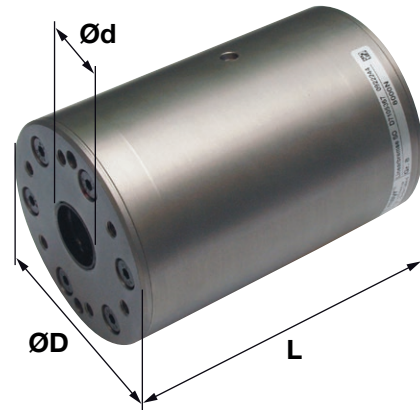

As a new brake system, the ROBA®-linearstop offers unique possibilities for increasing the safety of machinery. As a compact brake unit it can be integrated into already existing machinery and system constructions easily, quickly and without extensive adjustment work. By mounting a second ROBA®-linearstop brake or by using an additional brake on the servomotor, a redundant brake system can be implemented easily.

The unit having a direct effect on the rod brakes independently from the drive system.

In linear motor axes, the ROBA®-linearstop prevents e.g. not only unpermitted height loss of the vertical carriage due to power failure or other malfunctions, but is also capable of braking dynamic movements safety in EMERGENCY STOP situations.

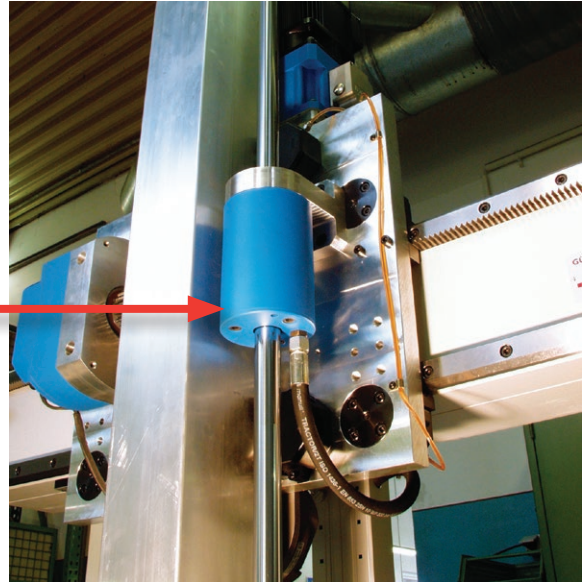
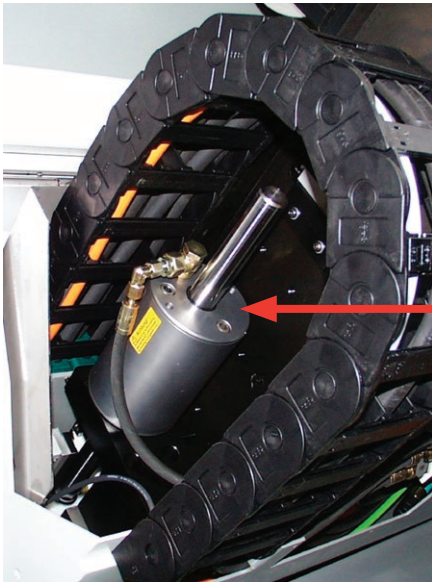

Technical Data, Dimensions			Size															
			Pneumatic brake system								Hydraulic brake system				Electromagnetic brake system			
			20	30	40	60	70	80	10	20	30	40	10	20	40	60	80	
Nominal holding force	F_N	[kN]	0.45	0.8	1.5	4.6	7.5	12.5	4	8	20	35	0.07	0.18	0.6	1.8	4.5	
			-1.2	-2.2	-4.4	-13.8	-22.5	-40	-10	-20	-35	-50		-0.55	-2.1	-6.5	-17.5	
Outer Ø	D	[mm]	46	56	70	110	140	178	91	112	140	170	35	50	75	110	160	
Brake rod Ø	d	[mm]	16	20	20	25	32	40	30	30	40	50	8	10	12	20	25	
Max. length	L	[mm]	147.9	152.9	157.9	184.5	213	246.6	131	163	172	189	40	169	189	224	270	

ROBA®-guidestop

Safety brake and backlash-free clamping unit for profiled rail guides

Performance Characteristics

- **Maximum safety thanks to direct, backlash-free and rigid clamping**
- **Maximum safety thanks to extremely high holding forces and fail-safe principle**
- **Powerpack with two brake circuits for double the holding force or redundant dimensioning**
- **Cost-efficient solution for limited installation space**
- **High degree of rigidity up to the full nominal force**
- **Extremely high holding forces**
- **Designed for standard linear guides**

The backlash-free and rigid clamping

- Reinforces the NC axis
- Is gentle on the ball screw spindle
- Improves process accuracy
- Increases the machining performance

Design

Integrated into a carriage, the ROBA®-guidestop works with two brake circuits independent of each other, and as a result can be used as a redundant dual circuit brake.

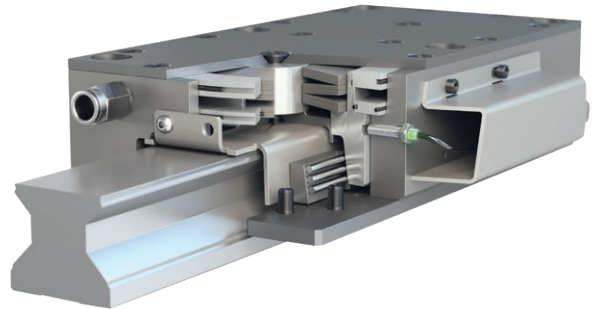
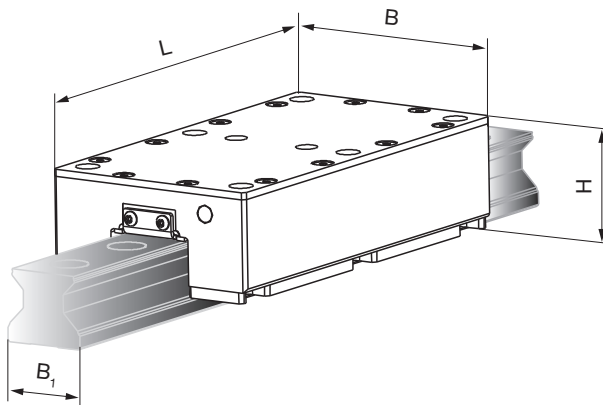

Function

The spring-loaded, enclosed ROBA®-guidestop, which can be opened hydraulically or pneumatically, clamps a profiled rail steplessly and backlash-free.

Due to the spring-loaded system, the fail-safe principle can be guaranteed, the ROBA®-guidestop works as a safety brake.

ROBA®-guidestop clamps with extremely high rigidity directly onto the linear guide.

The direct clamping on the linear guide provides decisive advantages, above all on gravity loaded axes, when the risk of injuries to people is to be minimized.

ROBA®-guidestop takes on the load when the vertical axis is stationary, for example during machining. In this phase, the drive motor can be switched off and removed from the control. Switching off the motor eliminates the regulating movements and thus is gentle on the ball screw spindle.

The additional reinforcement of the NC axis increases process accuracy, increases the machining performance and can offer other technological advantages, for example during heavy machining. The machining process is lower in vibrations and thus improves the surface quality.

Technical Data, Dimensions Standard				Size								
				Pneumatic brake system					Hydraulic brake system			
				25	35	45	55	65	35	45	55	65
Nominal holding force	F_N	[kN]	1.4 – 2.2	2.8 – 4.4	4.0 – 6.0	6.0 – 9.0	8.0 – 12.0	10	15	20	34	
Brake	Length	L [mm]	145	192	225	270	325	192	225	270	325	
	Height	H [mm]	40.2	50.7	59	72.3	86.7	50.7	59	72.3	86.7	
	Width	B [mm]	70	100	120	140	170	100	120	140	170	
Rail	Width	B_1 [mm]	23	34	45	53	63	34	45	53	63	

For detailed technical data and dimensions, please see brochure:

ROBA®-guidestop P.380000.V_..._

ROBA-stop®-silenzio®

The quietest safety brake for elevator and stage drives

Performance Characteristics

- Noise level of the basic version under 60 dB(A) even after several million switchings
- Dual circuit brake as redundant brake system brake in accordance with DGVV Rule 115-002 (previously BGV C1), DIN 56950-1, EN 81-A3 and other international standards
- Very short construction length
- Simplest possible installation
- No air gap adjustment necessary
- Microswitch or proximity switch can be mounted for release monitoring
- Brakes can be individually switched and inspected
- Type examination tested

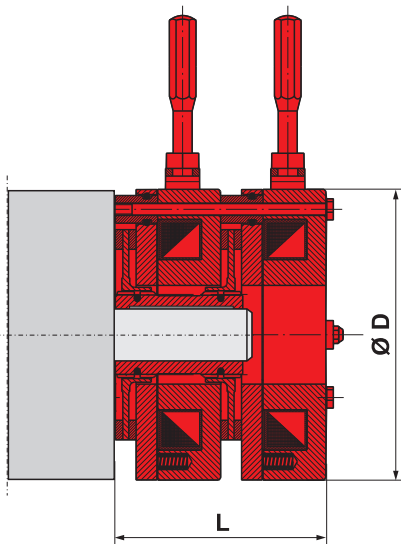

Dual circuit brake
Redundant brake system with two brake bodies working independently of each other

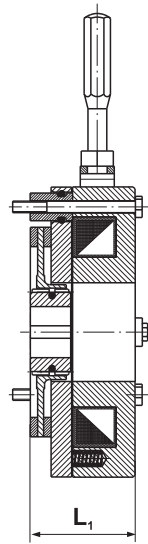

Single circuit brake
Compact brake with an extremely short construction length

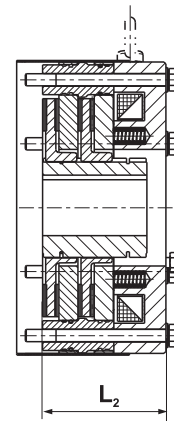

Double rotor design
Single circuit brake with two rotors (4 friction surfaces) with doubled braking torque

Technical Data, Dimensions			Size												
			4	8	16	32	64	100	200	300	500 ²⁾	800 ²⁾	1300	1800	
Max. braking torque ¹⁾	Dual circuit brake	M [Nm]	2 x 5	2 x 10	2 x 19	2 x 40	2 x 77	2 x 120	2 x 240	2 x 360	2 x 600	2 x 1000	2 x 1560	2 x 2150	
	Single circuit brake	M [Nm]	5	10	19	40	77	120	240	360	600	1000	1560	2150	
	Double rotor design ²⁾	M [Nm]	-	-	-	-	-	-	-	720	1200	2000	3120	4300	
Shaft Ø	min. - max.	[mm]	8 - 15	9 - 20	14 - 24	18 - 30	18 - 35	18 - 46	23 - 50	24 - 60	40 - 70	45 - 75	56 - 90	66 - 100	
Outer Ø	D	[mm]	88	108	130	153	168	195	223	261	285	329	370	415	
Length	Dual circuit brake	L	[mm]	87	91	99	109	127	134	152	159	172	189	199	205
	Single circuit brake	L ₁	[mm]	43.5	45.5	49	54.5	63.5	67	76	79.5	86	94.5	99.5	102.5
	Double rotor design	L ₂	[mm]	-	-	-	-	-	-	-	109.4	120.6	133.7	143.7	148.7

1) Tolerance +60 %

2) At max. braking torque adjustment (120 %), overexcitation (1.5 to 2 x the nominal voltage) is required for safe and fast release, using our ROBA®-switch fast acting rectifier (please contact mayr® power transmission if necessary).

ROBA®-diskstop®

The electromagnetic safety brake system for brake disks

Performance Characteristics

- Operation without rubbing noise due to unique patented alignment mechanism
- Attractive solution for large braking torques
- Minimum-noise operation
- Redundancy according to EN 81 when assembling two brakes
- Brakes can be individually switched and inspected
- Type examination tested
- High performance density

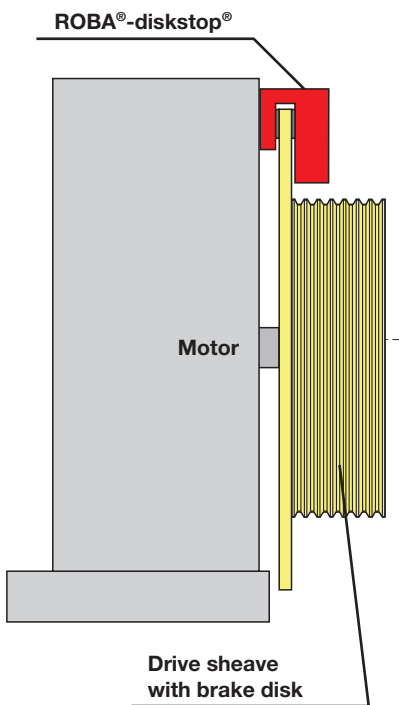
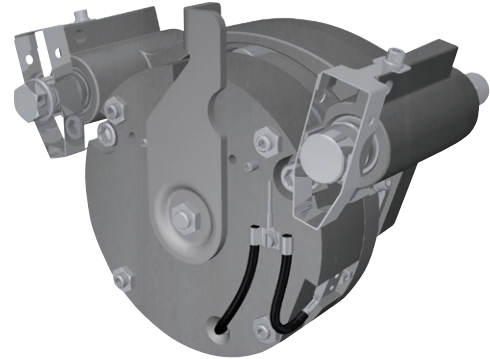

Sizes 6 – 8

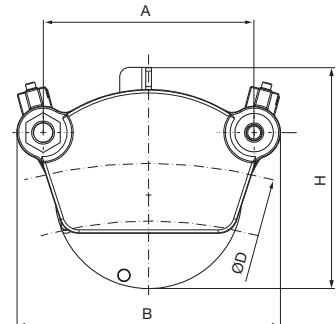
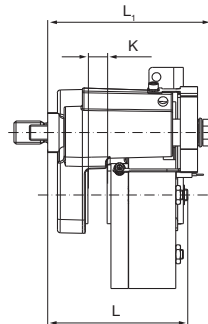

Sizes 9 – 10

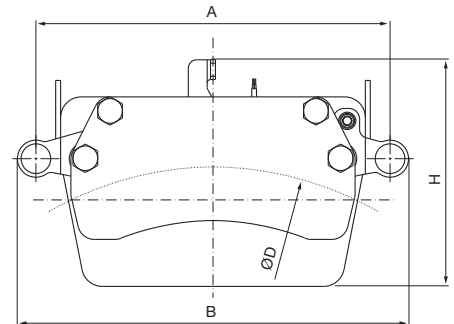
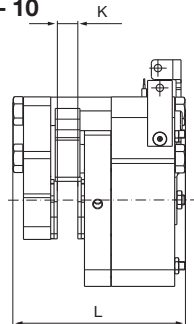

Technical Data, Dimensions			Size				
			6	7	8	9	10
Braking torque ¹⁾ "performance-optimized"	M	[Nm]	1551	1774	2323	4025	5144
			Example for brake disk diameter D = 1000 mm				
Braking torque ¹⁾ "noise-optimized"	M	[Nm]	1241	1416	1858	-	-
			Example for brake disk diameter D = 1000 mm				
Brake disk	Outer diameter	D [mm]	270 – ∞	390 – 1500	390 – ∞	600 – 1200	650 – 1500
	Width ²⁾	K [mm]	15	15	20	25	25
Brake	Bolt distance	A [mm]	140	180	220	400	430
	Length	L [mm]	139	135	148	184	206.5
	Length (with alignment mechanism for Sizes 6 – 8)	L ₁ [mm]	161	161	173	-	-
	Height	H [mm]	198	225.5	230.5	298	309
	Width	B [mm]	184	229	275	445	474

1) Tolerance -0 % / +60 %

2) Other brake disk widths are possible

For detailed technical data and dimensions, please see catalogue:

ROBA®-diskstop® K.894.V_..._

ROBA®-duplostop®

The doubled safety brake for elevator machines

Performance Characteristics

- Highest safety system of two independent brake circuits according to EN 81
- Also licensed as protection against excessive upward speeds when fitted with release monitoring
- Exceptionally short construction
- Cost-effective redundant elevator brake
- Brakes can be individually switched and inspected
- Mounting the encoder does not lengthen the construction
- Simple installation
- No air gap adjustment necessary
- Virtually silent due to patented *mayr*® noise damping
- Brake release via rotating hand release (for Bowden cable or with hand release lever) is a possible option

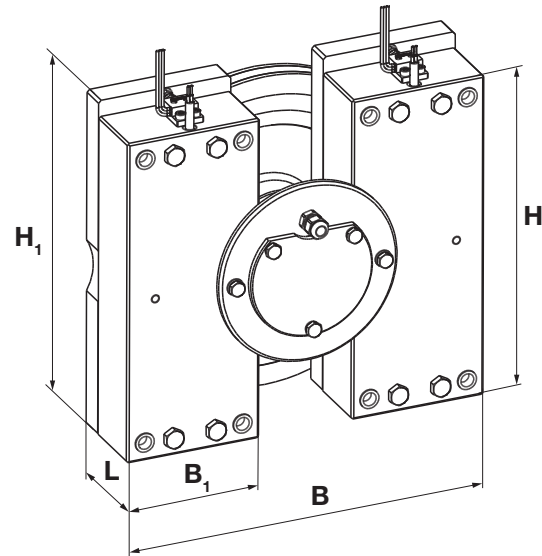

Technical Data, Dimensions			Size						
			200	400		600	800	1000	1500
				short	long				
Braking torque ¹⁾		M [Nm]	2 x 200	2 x 410	2 x 430/480	2 x 590	2 x 830	2 x 1015	2 x 1700
	(with overexcitation)	M [Nm]	2 x 240	–	2 x 490/540	2 x 670	2 x 930	2 x 1200	–
Shaft Ø	Directly toothed motor shaft DIN 5480 ^{2), 3)}	[mm]	60 x 2.5 x 22	65 x 3 x 20	72 x 3 x 22	72 x 3 x 22	82 x 3 x 26	90 x 3 x 28	95 x 3 x 30
		[mm]	65 x 3 x 20	67 x 3 x 21	82 x 3 x 26	82 x 3 x 26	90 x 3 x 28*	98 x 4 x 23*	98 x 4 x 23
		[mm]	67 x 3 x 21	72 x 3 x 22	90 x 3 x 28	–	98 x 4 x 23*	–	–
Brake	Length (with rotor)	L [mm]	86.1/91.1*	96.1	101.1	101.1	108.1	108.1	116
	Height	H [mm]	244	268	290	298	336	380	458
		H ₁ [mm]	256	280	303	311	349	393	458
	Width	B [mm]	270	315	290/355	355	375	395	480
Single brake		B ₁ [mm]	100	120	120	140	150	160	200

1) Tolerance +60 % 2) Design with toothed hub available on request 3) Spline length on request *) Dimension valid for braking torque with overexcitation

ROBA®-twinstop®

The dual-circuit safety brake for elevator machines

Performance Characteristics

- Highest safety system of two independent brake circuits according to EN 81
- Also licensed as protection against excessive upward speeds when fitted with release monitoring
- Exceptionally short construction
- Cost-effective redundant elevator brake
- Brakes can be individually inspected electrically
- Mounting the encoder does not lengthen the construction or add further parts
- Installation of microswitches for function monitoring possible
- No air gap adjustment necessary
- Virtually silent due to patented *mayr*® noise damping
- Brake release via rotating hand release (for Bowden cable or with hand release lever) is a possible option

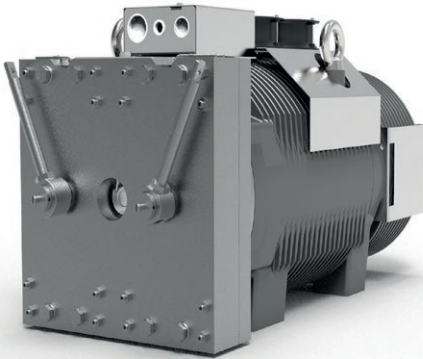
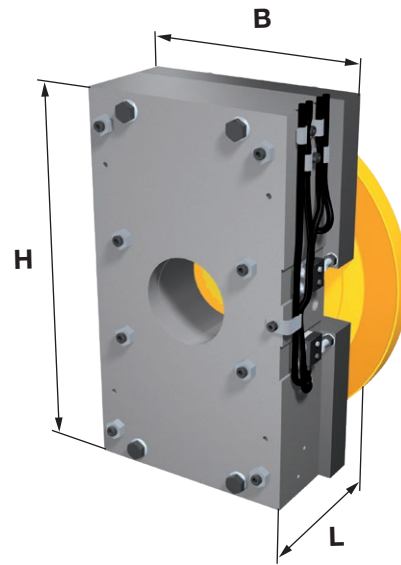

Design

The ROBA®-twinstop® consists of a compact brake block with two independent brake circuits which is fixed to the motor using four screws. In comparison to brake systems with brakes which are positioned behind each other, it has an extremely short construction length. Even the addition of a compact encoder does not alter this length, as it is located in the central bore.

Function

The redundant electromagnetic safety brake ROBA®-twinstop® is spring applied. If the power is switched off, or on power failure / EMERGENCY STOP, the brake ensures reliable and secure stops in any position.

Technical Data, Dimensions			Size												
			125	150	180	225		250	350	450	600	800	1000	2000	
Nominal braking torque	M_N	[Nm]	2 x 125	2 x 150	2 x 180	2 x 225	2 x 250	2 x 250	2 x 350	2 x 500	2 x 600	2 x 850	2 x 1200	2 x 2200	
Shaft Ø	Directly toothed motor shaft	[mm]	45 x 2	55 x 2	50 x 2	55 x 2	55 x 2	65 x 3	65 x 3	- ²⁾	72 x 3	80 x 3	90 x 3	- ²⁾	
	DIN 5480 ¹⁾		x 21	x 26	x 24	x 26	x 26	x 20	x 20		x 22	x 25	x 28		
Brake	Length (with rotor)	L	[mm]	85.6	90.6	92.6	97.6	97.6	100.6	100.6	110.5	102.6	112	131	135
	Height	H	[mm]	212	250	237	267	267	290	300	313	303	352	380	425
	Width	B	[mm]	200	170	200	200	200	170	210	250	315	320	340	410
	Rotor	R	[mm]	181	223	196	196	222.5	253	273	253	315	315/338	338	418

1) Design with toothed hub available on request

2) Sizes 450 and 2000 available on request

ROBA®-quatrostop

The extremely compact multiple-circuit brake for stage technology

Performance Characteristics

- Highest safety due to redundant system
- Braking torque is not doubled
- Reduces loads on the mounted parts
- Allows lighter connection constructions
- Low-noise operation
- Brakes gently
- Switches extremely quickly
- Saves costs
- Integrated, protected sensors can be mounted

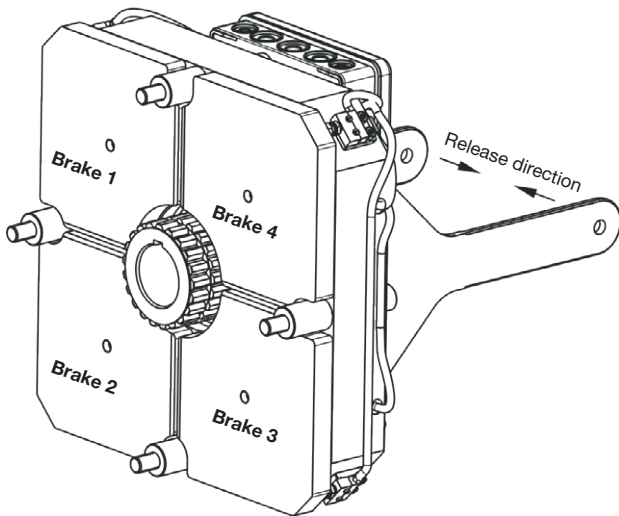
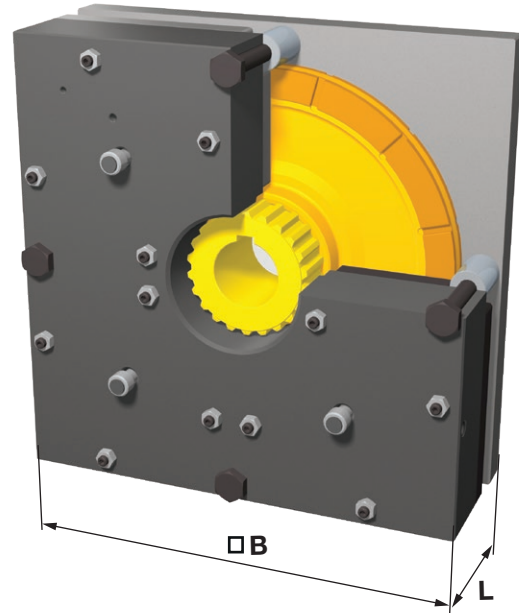

Low increase in braking torque due to four individual brake circuits

On redundant systems with two brake circuits, one circuit must produce the entire nominal braking torque required. If both brakes are functioning correctly, the increase in braking torque is 100 percent. The system brakes with double the nominal braking torque.

In the new ROBA®-quatrostop braking system, four brake circuits work independently of each other. Together, three brake circuits produce the required nominal braking torque. The fourth circuit ensures the necessary redundancy, in order to fulfil the safety requirements for elevator technology. In malfunction-free operation, the system has a braking torque increase of a mere 33 percent.

Technical Data, Dimensions			Size		
			200		
Nominal braking torque minimum	M_N [Nm]	4 x 50 (150 + 50)	4 x 55 (165 + 55)	4 x 67 (201 + 67)	
Shaft Ø		[mm]	38		
Brake	Length	L [mm]	92.5		
	Height	B [mm]	261		
	Width				

ROBA-stop®-stage

The redundant stage brake - without double the braking torque

Performance Characteristics

- Dual circuit brake without braking torque doubling
- Contactless release monitoring
- Reduces loads on supporting structures
- Meets all safety requirements in accordance with DIN EN 17206
- Certified by TÜV Süd, the Southern German Technical Inspectorate
- Ready-to-install plug-and-play solution
- High operational safety
- Low-noise operation
- Plug-in emergency hand release
- Maintenance-free
- Short switching times

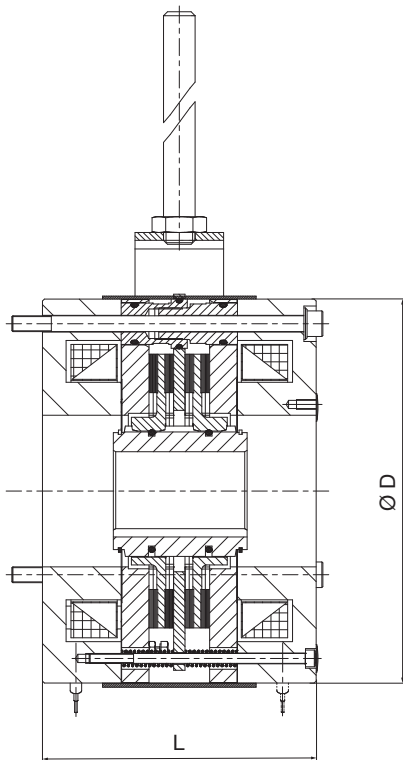
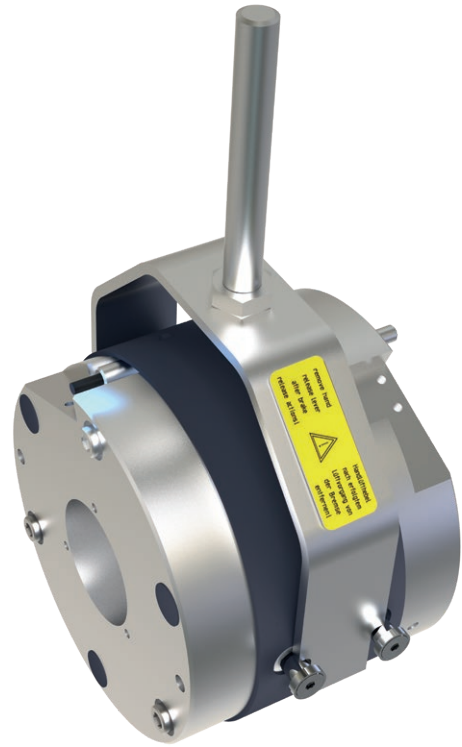

Single braking torque - double safety

In the new ROBA®-stop-stage braking system, two individual brake circuits operate to provide the necessary redundancy and thus meet the safety requirements of stage technology.

However, the special design means that the braking torque is not doubled during emergency braking. Without doubling the braking torque, the brakes work softly and are gentle on the components. At the same time, they ensure maximum safety for people and material.

The stage brakes are extremely compact due to their special design. Thanks to their lower braking torque, they also make it possible to reduce the overall size of the systems - for example, a smaller gearbox size can be selected.

In addition, the ROBA-stop®-stage brakes are equipped with a plug-in hand release, which allows both brake circuits to be opened at the same time in an emergency.

Technical Data, Dimensions			Size						
			8	16	32	64	100	200	
Braking torque	maximum	M _N	[Nm]	16	32	64	120	200	365
	reduced		[Nm]	13	28	58	100	180	310
	minimum		[Nm]	10	24	52	80	160	260
Shaft Ø	min. - max.		[mm]	9 - 20	14 - 22	15 - 29	18 - 32	20 - 46	25 - 50
Brake	Outer Ø	D	[mm]	108	130	153	168	195	223
	Length	L	[mm]	93.8	102.8	113.2	132.4	139.1	157

For detailed technical data and dimensions, please contact the manufacturers.

ROBA-stop[®]-Universal

The multifunctional all-round safety brake

Performance Characteristics

- Sensitive braking torque adjustment
- Simple wear re-adjustment
- Designs as positioning brake, holding brake, tacho brake and peak load brake
- Enclosed construction
- Simple installation
- Class of insulation F
- Can be used for 100 % duty cycle
- Short switching times

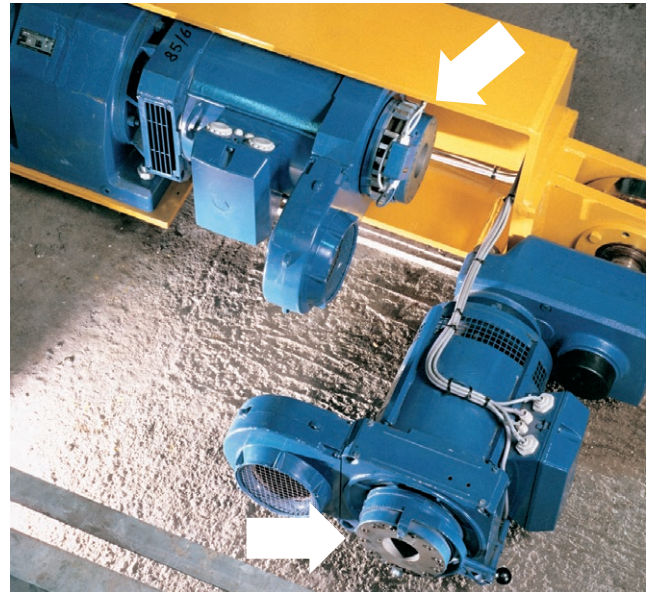
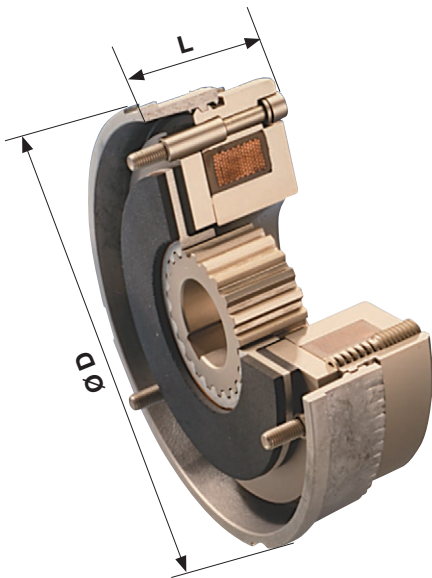

ROBA-stop[®] application in a high rack warehouse

Designs

- **ROBA-stop[®]-positioning brake**
Brake as dynamic brakes from movement and offer high positioning and repetitive accuracy.
- **ROBA-stop[®]-holding brake**
Achieve very high braking torques and hold drives safely in position when they are not running.
- **ROBA-stop[®]- tacho brakes**
Feature a centering recess and tapped holes on the back of the brake for mounting a tacho-generator.
- **ROBA-stop[®]-tacho peak load brakes**
Allow a tacho-generator to be mounted and have a special armature disk for high friction work.
- **ROBA-stop[®]- peak load brakes**
Have a special, extremely strong armature disk which allows high friction work.

Technical Data, Dimensions				Size									
				2	3	4	5	6	7	8	9	10	11
Braking torque ¹⁾		M	[Nm]	1.1	3	6	12	26	50	100	200	400	800
	Holding brake	M	[Nm]	–	5	10	22	48	90	180	360	620	1250
Shaft Ø			[mm]	6 – 11	8 – 12	10 – 15	10 – 20	15 – 25	20 – 32	25 – 45	25 – 50	25 – 60	30 – 80
	Holding brake		[mm]	–	8 – 12	10 – 15	10 – 20	15 – 25	20 – 32	25 – 45	30 – 50	30 – 60	30 – 80
Brake	Outer Ø	D	[mm]	59	79	98	114	142	165	199	220	275	360
	Length	L	[mm]	28	30.2	32.2	39.3	43.2	58.2	66.7	74.3	96.3	116.3
	Length peak load brake	L	[mm]	–	–	–	–	–	68.2	77.7	87.3	116.3	138.3

1) Tolerance +40 % / -20 %

ROBA-stop[®]-S

The waterproof, robust monoblock brake

Performance Characteristics

- **Completely enclosed and sealed design in Protection IP67**
- **Robust, single-part monoblock housing**
- **All components are corrosion-resistant**
- **High friction work is permitted**
- **Can be used in extreme ambient conditions**
- **Long-distance diagnosis via integration of release monitoring and wear monitoring**
- **Anti-condensation heating system to avoid condensation formation inside the brake**

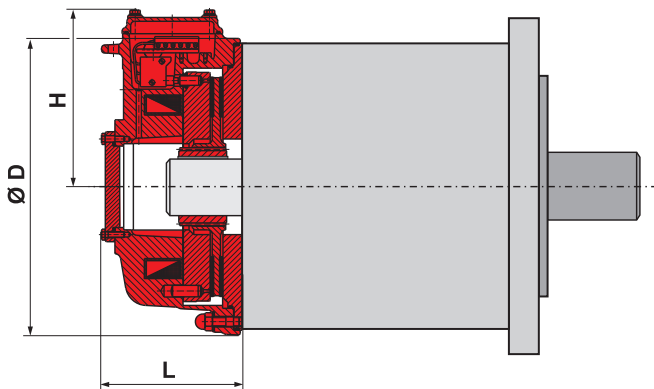

Application fields

- Harbour/ship/seawater
- Outdoor applications
- Steel works
- Crane systems
- Heavy industries
- Recycling plants
- Environmental technology

Technical Data, Dimensions			Size			
			8	9	10	11
Braking torque ¹⁾	M	[Nm]	100	200	400	800
Shaft Ø		[mm]	25 – 45	25 – 50	25 – 60	55 – 75
Brake	Outer Ø	D [mm]	240	270	310	450
	Length	L [mm]	122	132.5	152	194.1
	Height of terminal box	H [mm]	155	167	185	217

1) Tolerance +40 % / -20 %

Supplying – Protecting – Monitoring – Checking

Electronic mayr® – DC Voltage Modules for Safety Brakes

Function	Supplying						Protecting
Module	Type 024.000.6 Half-wave Rectifier	Type 025.000.6 Bridge Rectifier	Type 017_00.2 ROBA®-switch	Type 017.110.2 ROBA®-switch	Type 018.100.2 ROBA®-switch 24V	Type 019_00.2 ROBA®-multiswitch	Type 070.000.6 Spark Quenching Unit
Overexcitation / Power reduction			X	X	X	X	
DC-side disconnection				X	X		
Mains/Input voltage	up to 600 VAC	up to 230 VAC	100 to 500 VAC	100 to 500 VAC	24 VDC	100 to 275 VAC 200 to 500 VAC	Max. 300 VDC
Output voltage/ Overexcitation voltage	up to 270 VDC dependent on the mains voltage VDC = 0.45 x VAC	up to 207 VDC dependent on the mains voltage VDC = 0.9 x VAC	90 to 450 VDC dependent on the mains voltage VDC = 0.9 x VAC	90 to 450 VDC dependent on the mains voltage VDC = 0.9 x VAC	24 VDC	90 VDC (Size 10) 180 VDC (Size 20) constant / independent of the mains voltage	
Nominal voltages			45 to 225 VDC dependent on the mains voltage VDC = 0.45 x VAC	45 to 225 VDC dependent on the mains voltage VDC = 0.45 x VAC	6 VDC 8 VDC 12 VDC 16 VDC	52 VDC (Size 10) 104 VDC (Size 20) constant / independent of the mains voltage	
Switching times			0.05 to 2 s	0.05 to 2 s	0.15 s / 0.45 s / 1 s / 1.5 s / 2.15 s	0.15 s / 0.45 s / 1 s / 1.5 s / 2 s	
Output current	4.0 A	2.5 A	3.0 A (at 250 VAC)	1.5 A	5.0 A	2.0 A (Size 10) 4.5 A (Size 20)	
Characteristics / Application	Standard application Compact construction	Standard application, preferred for noise-damped brakes Compact construction	Short separation time	Short separation time and short connection time	Short separation time and short connection time No wear on contacts	Short separation time Consistently controlled output voltage with variable input voltage	Reduces switch-off voltage and wear on contacts

Monitoring		Monitoring and Supplying			Checking / Controlling and Monitoring	Safe Control and Monitoring
Type 058.600.2 ROBA®-brake-checker DC	Type 059.500.2 ROBA®-brake-checker AC	Type 028.100.2 ROBA®-brake-checker plus DC	Type 028.600.2 ROBA®-brake-checker plus DC	Type 029.700.2 ROBA®-brake-checker plus AC	Type 068.200.2 ROBA®-torqcontrol DC	Type 021.100.2 ROBA®-SBCplus
		X	X	X	X	X
		X	X		X	X
Max. 50 VDC	Max. 207 VDC ¹⁾ Max. 432 VDC ¹⁾	24 VDC (Size 2) 48 VDC (Size 4)	24 VDC	200 to 480 VAC	24 VDC or 48 VDC	24 VDC or 48 VDC
dependent on the supply	dependent on supply ¹⁾	24 VDC (Size 2) 48 VDC (Size 4)	24 VDC	104 / 52 VDC 207 / 104 VDC 185 / 104 VDC 360 / 185 VDC	24 VDC or 48 VDC	24 VDC or 48 VDC
dependent on the supply	dependent on supply ¹⁾	4 / 6 / 8 / 12 / 16 VDC (Size 2) 8 / 12 / 16 / 24 / 32 VDC (Size 4) constant / independent of the supply voltage	4 / 12 / 16 VDC further voltages available on request	52 VDC 104 VDC 185 VDC	4/6/8/12/16 VDC (24 VDC) 8/12/16/24/32 VDC (48 VDC) constant / independent of the supply voltage	6 VDC 8 VDC 12 VDC 16 VDC 24 VDC 32 VDC
		adapted to brake specifications	adapted to brake specifications	adapted to brake specifications	adapted to brake specifications	0.1 s to 2.5 s
10 A	3.5 A	10.0 A (Size 2) 5.0 A (Size 4)	5.0 A	2.0 A	10.0 A (24 VDC) 5.0 A (48 VDC)	24 VDC/2x5.5 A 48 VDC/2x2.75 A
Integrated release and drop-out recognition Brake status display Preventative function monitoring	Integrated release and drop-out recognition Brake status display Preventative function monitoring ¹⁾ Supply with half-wave rectifier, bridge rectifier or ROBA®-switch not via ROBA®-multiswitch	Integrated release and drop-out recognition Brake status display Short separation time and short connection time No wear on contacts Preventative function monitoring	Integrated release and drop-out recognition Brake status display Short separation time and short connection time No wear on contacts Preventative function monitoring	Integrated release and drop-out recognition Brake status display Short separation time and short connection time Preventative function monitoring	Setting of spring force and braking torque Integrated release and drop-out recognition Brake status display Short separation time and short connection time No wear on contacts	Controlling and monitoring up to two ROBA-stop® safety brakes, particularly in applications with requirements on personal protection according to standards on Functional Safety such as for example ISO 13849 and IEC 62061

Headquarters

Chr. Mayr GmbH + Co. KG
Eichenstraße 1, D-87665 Mauerstetten
Tel.: +49 83 41/8 04-0, Fax: +49 83 41/80 44 21
www.mayr.com, E-Mail: public.mayr@mayr.com



Service Germany/Austria

Baden-Württemberg

Esslinger Straße 7
70771 Leinfelden-Echterdingen
Tel.: 07 11/78 26 26 40
Fax: 07 11/78 26 26 39

Bavaria

Industriestraße 51
82194 Gröbenzell
Tel.: 0 81 42/50 19 808

Chemnitz

Bornaer Straße 205
09114 Chemnitz
Tel.: 03 71/4 74 18 96
Fax: 03 71/4 74 18 95

Franken

Unterer Markt 9
91217 Hersbruck
Tel.: 0 91 51/81 48 64
Fax: 0 91 51/81 62 45

Kamen

Herbert-Wehner-Straße 2
59174 Kamen
Tel.: 0 23 07/24 26 79
Fax: 0 23 07/24 26 74

North

Schiefer Brink 8
32699 Extertal
Tel.: 0 57 54/9 20 77
Fax: 0 57 54/9 20 78

Rhine-Main

Kohlhäuser Str. 3-5
36043 Fulda
Tel.: 06 61/96 21 02 15

Austria

Pummerinplatz 1, TIZ I, A27
4490 St. Florian, Austria
Tel.: 0 72 24/2 20 81-12
Fax: 0 72 24/2 20 81 89

Branch office

China

Mayr Zhangjiagang
Power Transmission Co., Ltd.
Fuxin Road No.1298, Yangshe Town
215637 Zhangjiagang
Tel.: 05 12/58 91-75 67
Fax: 05 12/58 91-75 66
info@mayr-ptc.cn

France

Mayr France S.A.S.
Z.A.L. du Minopole
Rue Nungesser et Coli
62160 Bully-Les-Mines
Tel.: 03.21.72.91.91
Fax: 03.21.29.71.77
contact@mayr.fr

Great Britain

Mayr Transmissions Ltd.
Valley Road, Business Park
Keighley, BD21 4LZ
West Yorkshire
Tel.: 0 15 35/66 39 00
Fax: 0 15 35/66 32 61
sales@mayr.co.uk

Italy

Mayr Italia S.r.l.
Viale Veneto, 3
35020 Saonara (PD)
Tel.: 049/879 10 20
Fax: 049/879 10 22
info@mayr-italia.it

Japan

Mayr Japan LLC
Higano Nihonbashi Building 2F,
1-1-9 Nihonbashi Kakigara-cho,
Chuo-ku Tokyo, 103-0014 Japan
Tel.: 03/35 27-29 00
Fax: 03/35 27-26 61
public.mayr@mayr.co.jp

Singapore

Mayr Transmission (S) PTE Ltd.
No. 8 Boon Lay Way Unit 03-06,
TradeHub 21
Singapore 609964
Tel.: 00 65/65 60 12 30
Fax: 00 65/65 60 10 00
info@mayr.com.sg

Switzerland

Mayr Kupplungen AG
Tobeläckerstraße 11
8212 Neuhausen am Rheinfall
Tel.: 0 52/6 74 08 70
Fax: 0 52/6 74 08 75
info@mayr.ch

USA

Mayr Corporation
10 Industrial Avenue
Mahwah
NJ 07430
Tel.: 2 01/4 45-72 10
Fax: 2 01/4 45-80 19
info@mayrcorp.com

Representatives

Australia

Drive Systems Pty Ltd.
8/32 Melverton Drive
Hallam, Victoria 3803
Australien
Tel.: 0 3/97 96 48 00
info@drivesystems.com.au

India

National Engineering
Company (NENCO)
J-225, M.I.D.C.
Bhosari Pune 411026
Tel.: 0 20/27 13 00 29
Fax: 0 20/27 13 02 29
nenco@nenco.org

Netherlands

Groneman BV
Amarilstraat 11
7554 TV Hengelo OV
Tel.: 074/2 55 11 40
Fax: 074/2 55 11 09
aandrijftechnik@groneman.nl

Poland

Wamex Sp. z o.o.
ul. Pozaryskiego, 28
04-703 Warszawa
Tel.: 0 22/6 15 90 80
Fax: 0 22/8 15 61 80
wamex@wamex.com.pl

South Korea

Mayr Korea Co. Ltd.
15, Yeondeok-ro 9beon-gil
Seongsan-gu
51571 Changwon-si
Gyeongsangnam-do. Korea
Tel.: 0 55/2 62-40 24
Fax: 0 55/2 62-40 25
info@mayrkorea.com

Taiwan

German Tech
Component Co., Ltd.
No.10-3, Ln. 358, Sec. 1,
Hemu Rd., Shengang Dist.,
429012 Taichung City
Tel.: +886 (4) 25150566
Fax: +886 (4) 25152413
abby@zfgta.com.tw

Czech Republic

BMC - TECH s.r.o.
Hviezdoslavova 29 b
62700 Brno
Tel.: 05/45 22 60 47
Fax: 05/45 22 60 48
info@bmc-tech.cz

Turkey

Representative Office Turkey
Kucukbakkalkoy Mah.
Brandium Residence R2
Blok D:254
34750 Atasehir - Istanbul, Turkey
Tel.: 02 16/2 32 20 44
Fax: 02 16/5 04 41 72
info@mayr.com.tr

More representatives:

Belgium, Brazil, Canada, Colombia, Croatia, Denmark, Finland, Greece, Hongkong, Hungary, Indonesia, Israel, Luxembourg, Malaysia, Mexico, New Zealand, Norway, Philippines, Portugal, Romania, Russia, Slovakia, Slovenia, South Africa, Spain, Sweden, Thailand

You can find the complete contact details for the representative responsible for your area in the Contact section at www.mayr.com

