

# Installation and Operational Instructions for Pneumatic Safety Brakes Size 11

(E006 11 206 001 4 EN)

Design according to  
Drawing number: E006 11 206 000 011  
Article number: 8223337

## Please read these Operational Instructions carefully and follow them accordingly!

Ignoring these Instructions may lead to malfunctions or to brake failure, resulting in damage to other parts.  
These Installation and Operational Instructions (I + O) are part of the brake delivery.  
Please keep them handy and near to the brake at all times.

### Contents:

- Page 1:** - Contents  
- Safety and Guideline Signs  
- Safety Regulations
- Page 2:** - Brake Illustrations
- Page 3:** - Brake Illustrations
- Page 4:** - Parts List  
- Technical Data
- Page 5:** - Function  
- Scope of Delivery / State of Delivery  
- Installation Conditions  
- Nominal Air Gap "a"  
- Brake Release Capacity  
- Temperature Monitoring
- Page 6:** - Brake Installation  
- Pneumatic Connection  
- Replacement of Worn Parts  
- Disposal  
- Malfunctions / Breakdowns

### Safety and Guideline Signs

#### CAUTION



Danger of injury to personnel and damage to machines.



**Please Observe!**  
Guidelines on important points.



According to German notation, decimal points in this document are represented with a comma (e.g. 0,5 instead of 0.5).

### Safety Regulations

These Installation and Operational Instructions (I + O) are part of the brake delivery.  
Please keep them handy and near to the brake at all times.



It is forbidden to start use of the product until you have ensured that all applicable EU directives, directives for the machine or system into which the product has been installed have been fulfilled.  
At the time these Installation and Operational Instructions go to print, the pneumatic brakes accord with the known technical specifications and are operationally safe at the time of delivery.  
Without a conformity evaluation, this product is not suitable for use in areas where there is a high danger of explosion. This statement is based on the ATEX directive.

#### CAUTION



- If the pneumatic brakes are modified.
- If the relevant standards for safety and / or installation conditions are ignored.

#### **User-implemented Protective Measures**

- Cover all moving parts to protect against seizure, dust or foreign body impact.

**To prevent injury or damage, only professionals and specialists should work on the devices, following the relevant standards and directives. Please read the Installation and Operational Instructions carefully before installation and initial operation of the device.**

**These Safety Regulations are user hints only and may not be complete!**

# Installation and Operational Instructions for Pneumatic Safety Brakes Size 11

(E006 11 206 001 4 EN)

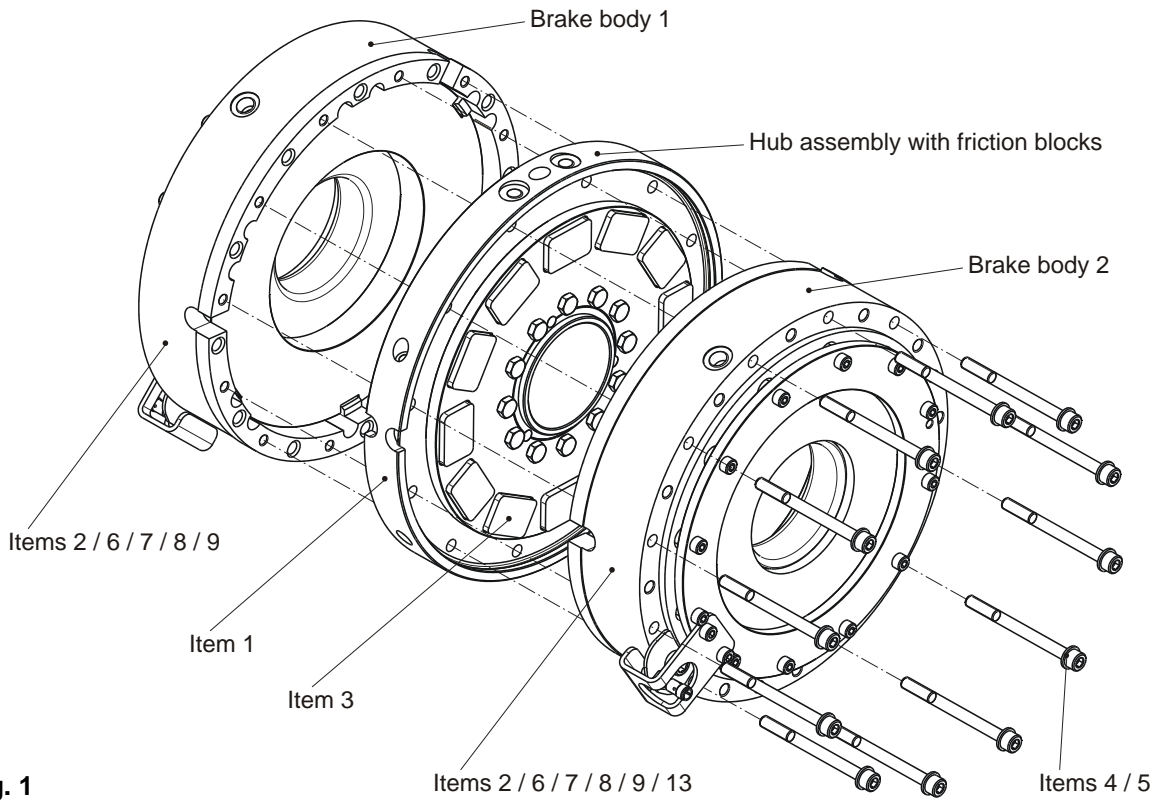

Fig. 1

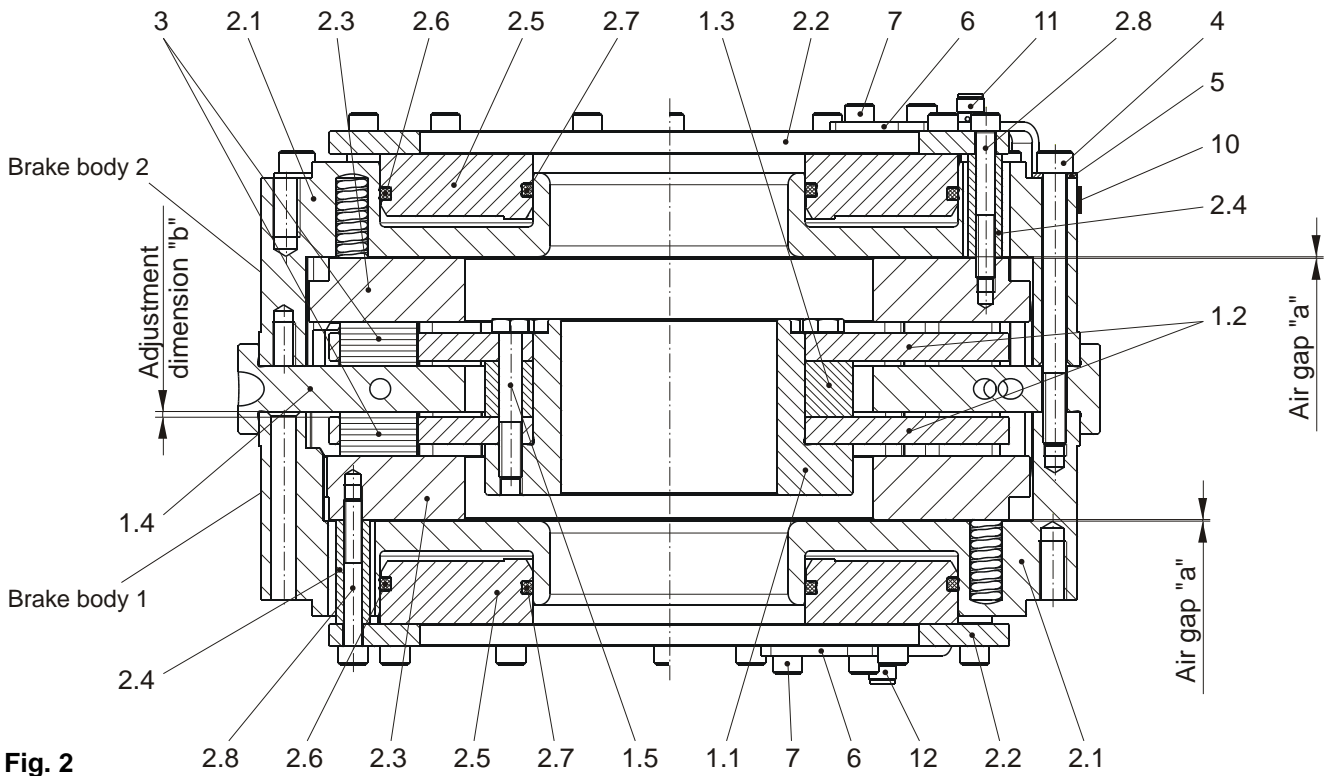

Fig. 2

# Installation and Operational Instructions for Pneumatic Safety Brakes Size 11

(E006 11 206 001 4 EN)

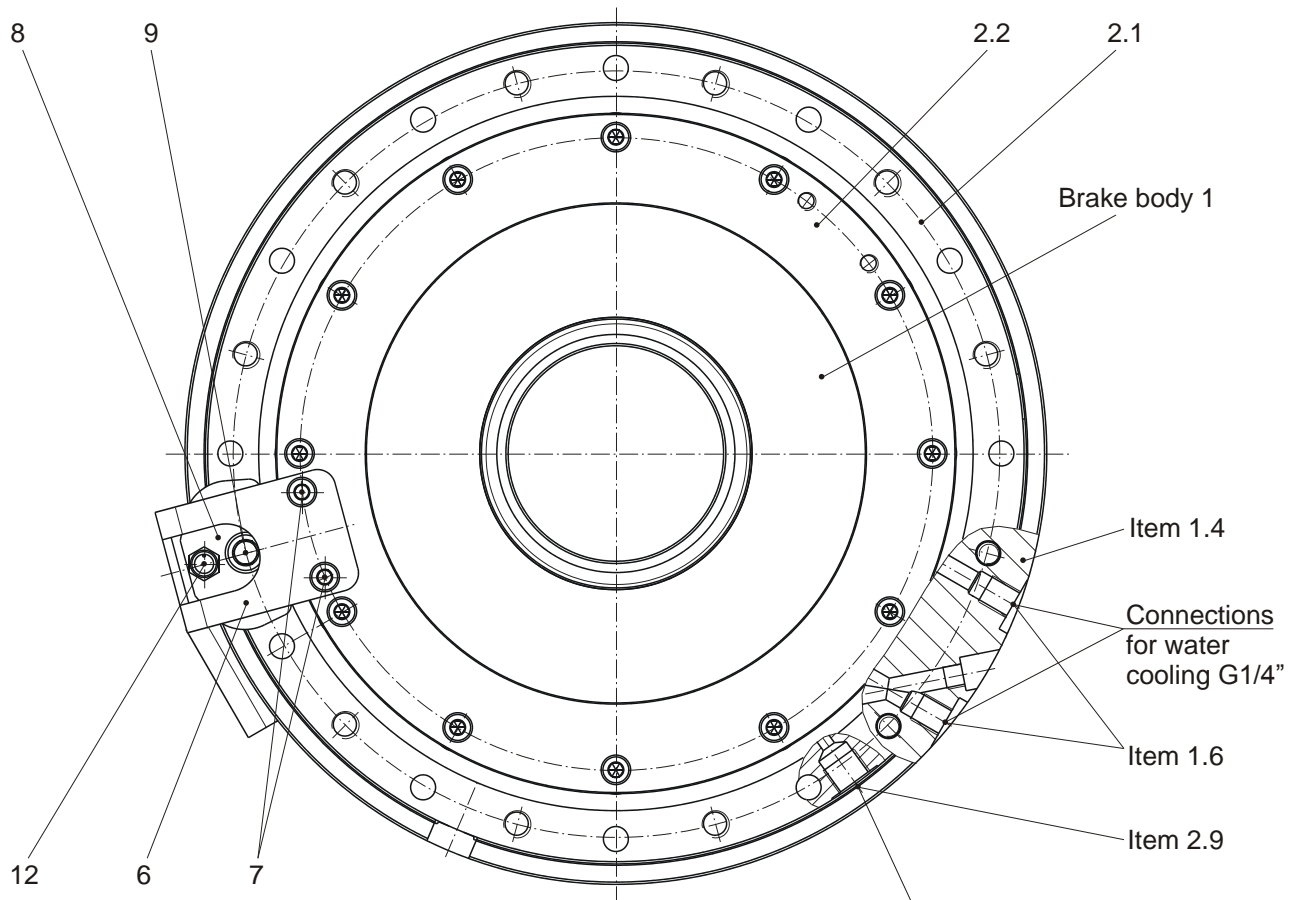

Fig. 3

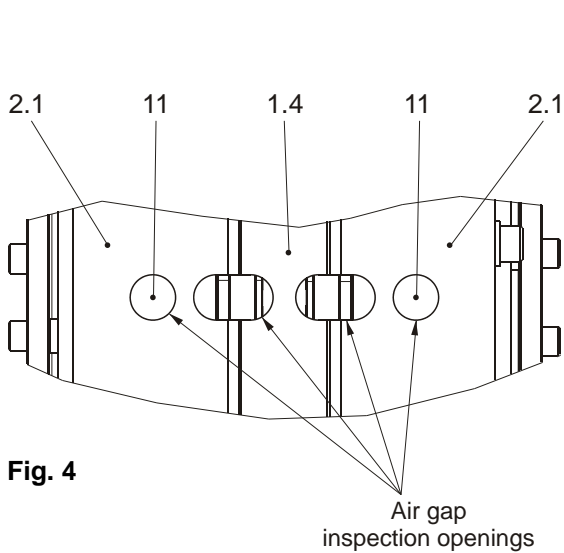

Fig. 4

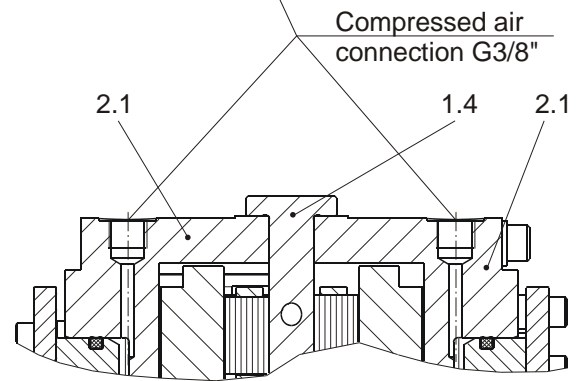

Fig. 5

# Installation and Operational Instructions for Pneumatic Safety Brakes Size 11

(E006 11 206 001 4 EN)

## Parts List (Only use *mayr*<sup>®</sup> original parts)

Item	Name	Pcs.
1	Hub assembly	1
1.1	Hub	1
1.2	Rotor	2
1.3	Intermediate ring	1
1.4	Intermediate disk	1
1.5	Hexagon head screw M10 x 65	12
1.6	Thread plug G1/4"	2
2	Cylinder assembly	2
2.1	Cylinder	2
2.2	Thrust ring	2
2.3	Armature disk	2
2.4	Distance sleeve	24
2.5	Piston	2
2.6	Quad ring D240,67 x 5,33	2
2.7	Quad ring D120,02 x 5,33	2
2.8	Cap screw M8 x 65	24
2.9	Thread plug G3/8"	2
3	Friction block	24
4	Cap screw M10 x 120	12
5	Washer A10,5	12
6	Bracket	2
7	Cap screw M8 x 10	4
8	Holding plate	2
9	Cap screw M12 x 16	2
10	Type tag	1
11	Sealing plug	4
12	Proximity switch (not included in the standard scope of delivery)	-
13	Screw plug	1

## Technical Data

<b>Braking torque:</b>	2200 Nm
<b>Max. speed:</b>	600 rpm
<b>Tightening torque (Item 4):</b>	71 Nm
<b>Compressed air connection:</b>	2 x G3/8"
<b>Connection for water cooling:</b>	G1/4"
<b>Operating pressure:</b>	5,5 – 8 bar
<b>Min. release pressure:</b>	5,2 bar
<b>Mass:</b>	128,9 kg
<b>Nominal air gap <sup>1)</sup> "a" (Figs. 2 + 3):</b>	0,7 <sup>+0,5</sup> mm
<b>Max. permitted air gap "a" (Figs. 2 + 3) after wear:</b>	1,6 mm
<b>Installation dimension "b" (Figs. 2 + 3):</b>	2,5 ±0,3 mm

# Installation and Operational Instructions for Pneumatic Safety Brakes Size 11

(E006 11 206 001 4 EN)

## Function

This dual circuit pneumatic safety brake is a brake, which is actuated via thrust springs. In de-pressurised condition, the thrust springs press both armature disk (2.3) including the piston (2.5) against the friction blocks (3) and the intermediate disk (1.4), thereby holding the drive element in braked condition. On application of compressed air (min. 5,2 bar), the armature disks (2.3) including the piston (2.5) are pressed against the thrust springs to the cylinder (2.1); therefore, the brake is torque-free.

## Scope of Delivery / State of Delivery

The brake is to be delivered as a completely pre-assembled unit. The screw connections of the two cylinder assemblies (4) including mounted parts are tightened to the tightening torque. Please check the scope of delivery according to the Parts List as well as the state of delivery immediately after receiving the goods. *mayr*® will grant no guarantee for belated complaints. Please report transport damage immediately to the deliverer. Please report incomplete delivery and obvious defects immediately to the manufacturer.

## Installation Conditions

- ❑ The eccentricity of the mounting pitch circle and the centering  $\varnothing$  315 in relation to the shaft end must not exceed 0,2 mm.
- ❑ The positional tolerance of the bores for the customer-side fixing screws M12 for brake installation must not exceed 0,4 mm.
- ❑ The max. screw-in depth in the cylinder (2.1) for the customer-side fixing screws M12 totals 26 mm.
- ❑ The minimum strength for the customer-side fixing screws M12 totals 10.9  
Recommended screw tightening torque: 122 Nm.
- ❑ The axial run-out deviation of the screw-on surface to the shaft must not exceed the permitted axial run-out tolerance of **0,063 mm** acc. DIN 42955 R. The centering diameter is the related diameter.
- ❑ The brake surfaces and friction blocks (3) must be oil and grease-free.

## Air gap "a" (Figs. 4 + 6)

The air gap "a" between the cylinder (2.1) and the armature disk (2.3) in de-pressurised condition can be determined using a feeler gauge after removal of the sealing plug (11). Two inspection openings are available per brake circuit for this purpose.

## Brake Release Capacity

During the course of installation, the release behaviour of the brake must be checked

1. Check the air gap "a".  
The nominal air gap  $0,7^{+0,5}$  mm must be given.
2. Check the installation dimension "b" =  $2,5 \pm 0,3$  mm  
Dimension "b" = Distance from the intermediate disk (1.4) to the rotor (1.2), as shown in Fig. 6.
3. After installation has been completed, apply 5.2 bar of compressed air to both brake circuits.  
The hub assembly (1) with the friction blocks (3) must be disengaged.

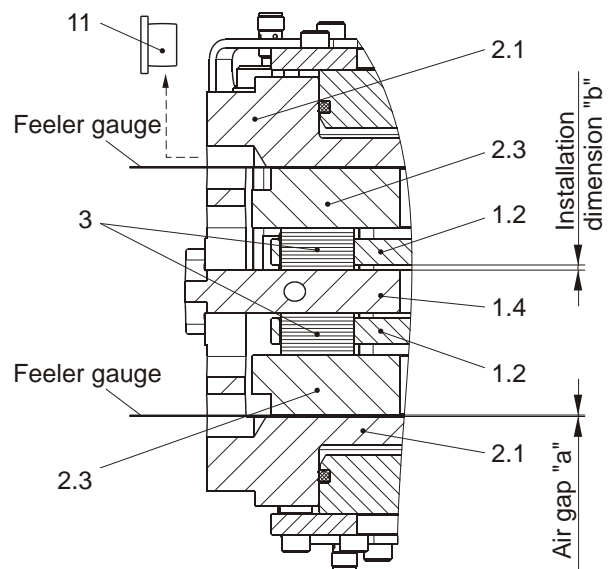

Fig. 6

## Temperature Monitoring (Fig. 7)

There is a thread in the cylinder (2.1) of brake body 2 M12 x 1,5 for a cable gland in order to mount a temperature monitoring device for the armature disk (2.3) provided by the customer. The max. temperature of the armature disk (2.3) may total 80 °C. In order to install the temperature monitoring device, the screw plug (13) must be removed.

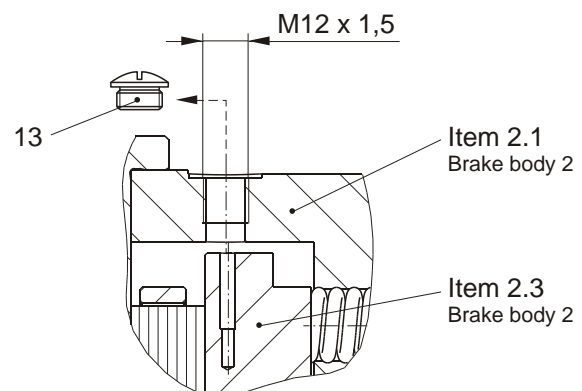

Fig. 7

# Installation and Operational Instructions for Pneumatic Safety Brakes Size 11

(E006 11 206 001 4 EN)

## Brake Installation (Figs. 1 to 6)



During installation, please ensure that the two brake bodies are aligned correctly with each other, see Figs. 1 and 3.

1. Deposit the pre-assembled brake onto brake body 1.
2. Loosen the cap screws (4) and remove them along with the washers (5).
3. Remove brake body 2.
4. Remove the hub (1) with all 24 friction blocks (3).
5. Fix brake body 1 onto the customer flange using 12 screws M12 (not included in the standard scope of delivery / secure screws using Loctite 243) to a **tightening torque of 122 Nm**, and then apply operating pressure.
6. Mount the hub assembly (1), equipped with 12 friction blocks (3) for brake circuit 1, onto the drive shaft, bring it into the correct position (observe installation dimension "b", see Fig. 6), and secure axially (e.g. using a clamping set).
7. Equip the second rotor (1.2) with 12 friction blocks (3).
8. Apply operating pressure to both brake bodies.
9. Screw brake body 2 using cap screws (Item 4 / secure screws using Loctite 243) and washers under them (5) output-side with brake body 1. Please observe the **tightening torque of 71 Nm!**
10. Connect the water cooling for the intermediate disk (1.4). Connections see Fig. 3.

## Pneumatic Connection (Figs. 3 and 5)

The threaded holes G3/8" for the pneumatic connection onto the cylinders (2.1) is sealed with screw plugs (2.9) to protect against dirt and other external influences.

In order to connect the brake, the screw plugs (2.9) must be removed.

The operating pressure (pressure for brake release) is 5,5 – 8 bar.

The minimum release pressure is 5,2 bar.

The compressed air quality must comply with DIN ISO 8573-1.

In case of oiled compressed air, use oil acc. ISO 3448 VG32.

The compressed air lines from the valve to the two cylinders (2.1) should be approximately equal in length.



When carrying out maintenance work or repair work, please make sure that the brake is not pressurized.

## Wear

As the friction blocks (3) wear down, the air gap "a" increases. The air gap "a" can be inspected using a feeler gauge, as described on page 5.

Replacement of the friction blocks (3) must take place at the latest at a max. air gap "a" of 1,6 mm.

When replacing the friction blocks (3), the state of the friction surfaces must be assessed. If they are run in substantially, the respective assemblies need to be replaced.

Replacement of the quad rings (2.6/2.7) must only be carried out by the manufacturer.

## Replacement of Worn Parts

**Parts subject to wear are:**

- Hub assembly (1)
- Cylinder assembly (2)
- Friction blocks (Item 3 / 1 set = 24 pieces)



De-installation of the cylinder assembly (2) must only be carried out by the manufacturer. The unit is subject to spring pre-tension.

## Disposal

Our pneumatic brake components must be disposed of separately as they consist of different materials. Please also observe the relevant authority regulations. Code numbers may vary according to the disassembling process (metal, plastic and cables).

**Electronic components** (proximity switch):

Products which have not been disassembled can be disposed of under Code No. 160214 (mixed materials) or components under Code No. 160216, or can be disposed of by a certified disposal firm.

**Steel components:**

Steel scrap (Code No. 160117)

**Friction blocks:**

Brake linings (Code No. 160112)

**Seals, O-rings, V-seals, elastomers:**

Plastic (Code No. 160119)

## Malfunctions / Breakdowns

Malfunction	Possible Causes	Solutions
Brake does not release	<input type="checkbox"/> Operating pressure too low <input type="checkbox"/> Leaking piston seals	<input type="checkbox"/> Increase operating pressure (min. 5,5 bar, max. 8 bar) <input type="checkbox"/> Replace the quad rings at the place of manufacture
Brake does not brake	<input type="checkbox"/> Air gap too large <input type="checkbox"/> Oil or grease on the friction surfaces	<input type="checkbox"/> Replace the friction blocks (3) <input type="checkbox"/> De-grease the brake surfaces



mayr® will take no responsibility or guarantee for replacement parts and accessories which have not been delivered by mayr®, or for damage resulting from the use of these products.